

## ***USER`S MANUAL***

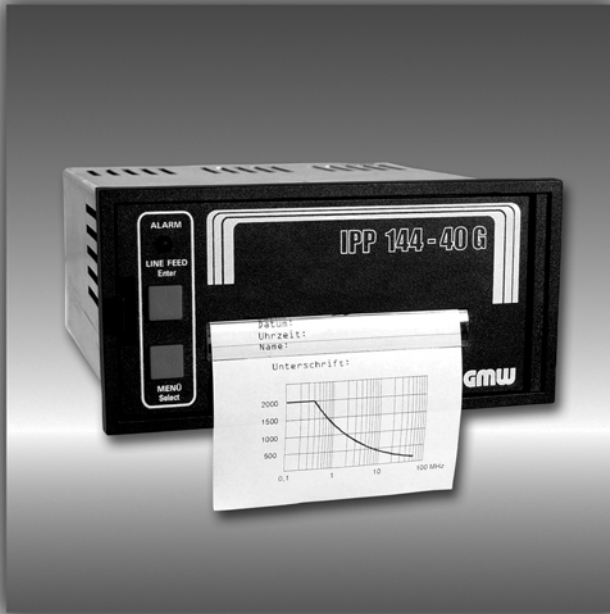

***Thermal Graphics Printers***  
***IPP 144 - 40 G***  
***IPP 144 - 40 GE***

***Paper Reroll Mechanism***  
***IPP - AW***

# Safety instructions (IEC 1010-1, Class I)

**In order to preclude any danger to the operator, the following instructions should be followed:**

- a) In case any damage or malfunction is detected, take the unit out of operation without delay.
- b) Before disassembling the unit, disconnect all inputs / outputs and the supply voltage. When mounting the unit and the connections, make sure all live components are protected from being touched directly.
- c) Comply with the usual regulations and safety provisions for low and high current systems, in particular country-specific safety provisions (e.g. VDE 0100).
- d) The maximum admissible potential existing between the pin groups as well as to the external protective conductor must not be exceeded. Refer to the unit's identification label.
- e) When connecting the unit to other devices (e.g. PCs), the connection must be carefully planned. Internal connections in external units (e.g. GND connected to protective earth) may cause excessive voltage potential.
- f) This device must be grounded! Used for the power line of the low current systems 12V<sub>DC</sub> and 24V<sub>DC</sub> screened cable. Units with a.c. voltage as supply voltage must be connected to the protective conductor.
- g) Make sure that the unit is properly mounted before connection and power on !

**In order to preclude any damage to the unit, the following items must be taken into account:**

The maximum admissible potential between the pin groups must not be exceeded.  
This applies in particular to high voltage tests.



**Refer to the instruction manual !**



**Warning: Hazardous live voltage !**

## **WARNING:**

There are always hazardous voltage present in certain parts during the operation of electrical equipment. Non-observance of the safety instructions can result in severe personal injury or damage to property. Only qualified personnel should work on this equipment. The successful and safe operation of this equipment is dependant on proper transport, storage, set-up, installation and careful operation and maintenance.

### **QUALIFIED PERSONNEL**

Are personnel who are familiar with the set-up, installation, commissioning and operation of the product and have the qualifications corresponding to their activities, e.g.:

- Are trained and authorised to energise, de-energise, clear, ground and tag circuits and equipment / systems in accordance with established safety standards.
- Are trained in the proper care and use of protective equipment in accordance with established safety practices.
- Are trained in first aid.

Safety according to EN 61010-1, VDE 0411

CAT III > 150 V ≤ 300 V

Pollution degree : 2; indoor use; altitude <2000 m; relative humidity <80 % up to 31 °C;  
Temperature: 5 °C to 40 °C;

# Table of Contents

	page		page
<b>I. IPP 144 - 40 G / IPP 144 - 40 GE</b>	<b>3 - 60</b>		
<b>1. General Features</b>	3 - 5	<b>8. Appendix</b>	40 - 60
<b>2. Technical Data</b>	6 - 9	8.1. Menu program - complete Selection	40 - 41
2.1. Basic Version	6 - 8	8.2. Character Sets	42 - 44
2.2. Version E	9	8.3. Details of Printer Control Commands	45 - 57
<b>3. Design and Installation</b>	10 - 11	8.3.1. Short View of Control Commands	45
<b>4. Connection</b>	11 - 17	8.3.2. Print Character Commands	45 - 48
4.1. Pin assignment	11 - 13	8.3.3. Print Position Commands	48 - 49
4.2. Interface selection	14	8.3.4. Bitmap image Commands	49 - 53
4.3. Connecting Diagram serial	15 - 17	8.3.5. Line Feed Commands	53
<b>5. Operation</b>	18 - 23	8.3.6. Barcode Commands	54 - 57
5.1. Operating Controls	18 - 19	8.4. Connection Examples for GMW instruments	58 - 59
5.2. Replacing the paper roll	20	8.4.1. Connection with DPM / MF	58
5.3. Menu program	21 - 23	8.4.2. Coupling with DAA	59
<b>6. Adjustments</b>	24 - 32	8.5. Examples for Automatic Text Insert Mode	60
6.1. General Functions	24 - 25	<b>II. Paper Reroll Mechanism IPP - AW</b>	61 - 64
6.2. Serial Interfaces	25 - 26	1. General information	61 - 62
6.3. Version E	26 - 32	Design / Installation	62
6.3.1. Text Enty	26 - 30	2. Technical data	63
6.3.2. Date / Time	30 - 32	3. Operation	64
<b>7. Functional Description</b>	32 - 39	<b>III. Accessories</b>	65
7.1. Start Printing	32		
7.2. Addressing	33 - 34		
7.3. Handshakes Messages	34 - 35		
7.4. Text Output (E-Version)	36 - 38		
7.4.1. Fixed Texts	36		
7.4.2. Automatic Text Enty	37 - 38		
7.5. Date / Time Output	38 - 39		

# Index

	page		page
Accessories	65	Operating controls, general	18
Addressing	26, 33	Paper	6
Addressing & protocol / text	34	Paper reroll mechanism	61
Automatic Text insert mode	37	Parameters, changing	22, 23
Basic version	5	Parameters, printing the current	21
Baudrate	25	Parity	25
Barcode Commands	54	Pin assignment current loop	16
Bitmap image Commands	49	Pin assignment - interface I	15
Character set	24, 42	Pin assignment - interface II	17
Connection diagrams	11	Print Character Commands	45
Connection Examples	58	Print Control Commands	44
Control characters	42	Print format	24
Data format - serial	25	Print interval - serial	34
Date / time - output via interface II	38	Print interval - setting	24
Date / time - setting	30	Print mechanism	6
End of paper indication	18	Print Position Commands	48
Environmental conditions	7	Protocol - serial	39
Expanded version (E - version)	5	Replacing the paper roll	20
Handshake serial - RTS / DTR	34	Snap lock	18
Handshake serial - XON / XOFF	34	Software version	8
Headline	39	Start printing	32
Input buffer	7	Technical Data	6
Installation	10	Text adding, overwrite	28
Interface selection	14	Text call - serial	35
Key LINE FEED / ENTER	18	Text call with measured data, serial	36
Key lock	19	Text - deleting	28
Key MENU / SELECT	18	Text entry	26
KEY RESET	19	Text entry - block	29
Line Feed Commands	53	Text entry - error messages	27
Line with (character per line)	24	Text entry - format	28
Mechanical data	8	Text entry termination	28
Menu program - complete selection	40	Text entry - wildcards	28
Menu program - entry	21	Text output - block	37, 60
Menu program - quitting	22	Voltage supply	7
Mode EDIT - keyboard/terminal	26	Wildcards for measure value	28
Mode FILE - PC	26	Windows-programing software	5
Model types	4	Write protection	19

# I. IPP 144 - 40 G / IPP 144 - 40 GE

## 1. General Features

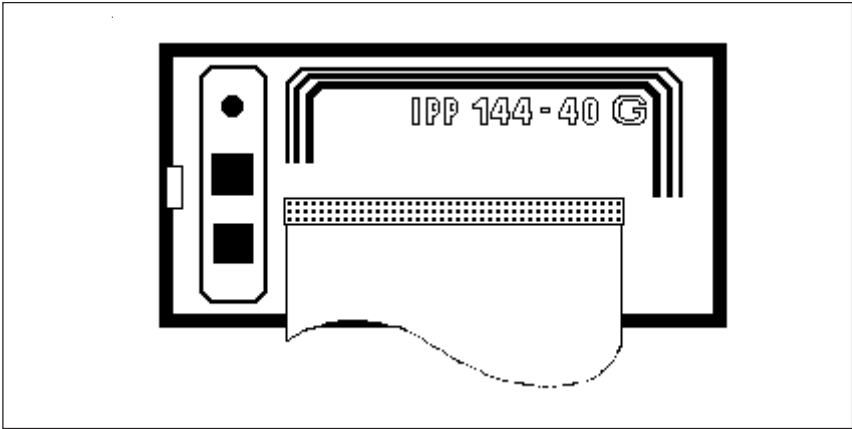

The Thermal Graphics Printer IPP 144-40 G (Industrial Process Printer) is a device designed for outputting text, data and graphics, i.e. measured value, machine and process states, error messages, production data, etc.

*Two application examples:*

- If connected to a digital voltmeter, the IPP 144-40 G records the measuring values (with date/time for the E version).
- Its integrated interface allow the use of the IPP 144-40 G as a peripheral for all PLCs (RS 232 C; RS 422; RS 485; USB; Profibus DP).

The Thermal Graphics Printer is a DIN size panel mounting unit which is able to print line widths of up to 48 characters per line. The 14m paper roll (commercial grade document proof thermo paper) is located inside the housing and can be easily replaced by means of a swivel type front panel. An end of paper indicator lights up if the printer runs out of paper.

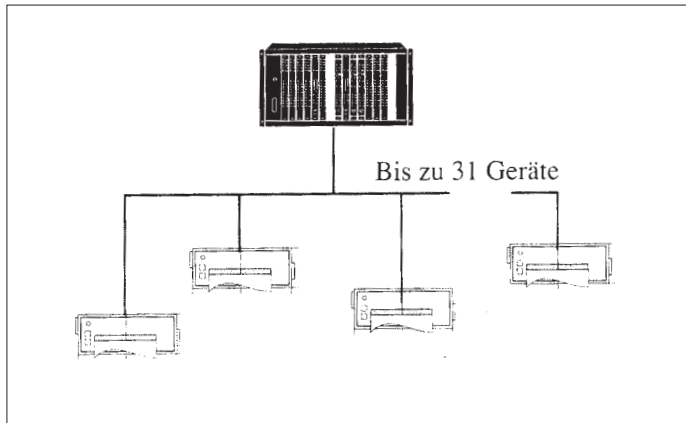

Each printer is addressable, which allows the connection of up to 31 devices to one sender device via a data line at the RS 485 interface, e.g. to a PLC.

**Review of the model types**

There are two version of the printer: The Basic Version IPP 144-40 G with the interface I and the Extended Version IPP 144-40 GE with the interfaces I and II.

There are three option for the voltage supply: 12V DC (10V...19V DC) or 24V DC (19V...36V DC) or 110V/230V AC (switched-mode power supply: 85V...265V AC)

There are four option for the interface III : RS 232 C or RS 485 or ProfiBus or USB

Modell	Spannungsversorgung			Interface I	Interface II
IPP 144-40 G	12V DC	24V DC	110-230V AC	Ja	Nein
IPP 144-40 GE 232	12V DC	24V DC	110-230V AC	Ja	RS 232 C
IPP 144-40 GE 485	12V DC	24V DC	110-230V AC	Ja	RS 485
IPP 144-40 GE PB	12V DC	24V DC	110-230V AC	Ja	ProfiBus
IPP 144-40 GE USB	12V DC	24V DC	110-230V AC	Ja	USB

The connector for the interface II of RS 232 C, RS 485 and ProfiBus is a 9 pin D-Sub-socket. It is possible to change this interface cards in the factory. The interface option USB has a special USB-B-socket. It is not possible to change this interface card with each other cards. Used in this situation special adapter cable and converter.

**Windows-Programming software**

For the printer has been developed a Windows-Programming software. This software will be available to programme the GE text memory, transfer user defined fonts or symbols and set the printer configuration parameters. Also this software package included actual Windows printer drivers. The software will be on CD-ROM.

**Grundversion IPP 144-40 G**

The basic version IPP 144-40 G provides one serial interface capable of receiving only. Return (handshake messages to the sender are sent via hardware line. Texts and measuring value to be printed must be transmitted from the sender device since the basic version does not have an internal text memory. It is possible to print with the basic version bitmap image and barcodes. The bitmap image files and the barcode files have been generated with printer control commands in a terminal program. This files are transmied by the interface i to the printer. It is possible to download this files on the font ROM chip in the printer. The printercontrol commands and download commands see section 8.3. in this manual.

Note: The cyrillic character set is on the font ROM chip. If user defined fonts or symbols will be downloaded on the font ROM chip, the cyrillic character set will be overwritten. The cyrillic character set will not longer been available.

**Erweiterte Version IPP 144-40 GE**

The extended version IPP 144 - 40 GE provides a second, bidirectinal serial interface capable of outputting return messages under program control in compliance with a protocol. In addition, this model includes a text memory capable of storing up to 15 texts which are called by specifying the corresponding text number. Moreover, date and time may be printed with texts and data. The printer interfaces of the IPP 144-40 GE can be set in the menu program as serial transfer or standard Windows printer drivers. So it is possible to print data (e.g.user defined fonts and symbols) directly with Windows.

It is not possible for the user to upgrade the basic version to the extended version; the extended version is a different factory version.

## 2. Technical Data

### 2.1. Basic Version

#### Print mechanism

Type of printing	Thermo line thermal
Character representation	576 dots/Line, 8 dots/mm
Print speed approx.	15 line/s (standard text mode)
Character/line	48 characters 24 characters 16 characters 8 characters
Character height	3 mm at 48 characters 4 mm at 24 characters 9 mm at 16 characters 18 mm at 8 characters
Character sets	ASC II, german, french, danish, norwegian, swedish / finnish, spanish, english, cyrillic
Service life	min. 10x10 <sup>6</sup> Impulse or 50 km

#### Paper

Type	commercial grade, document proof thermo paper
Width	80 mm (+0 / -1 mm)
Length	approx. 14 m (approx. 4.600 line up to 48 characters per line)
Max. outer roll diameter	40 mm
Min. inner roll diameter	11,5 mm
Temperature	standard paper: 0 °C to 60 °C

<b>Input buffer</b>	Seriell	16 kB
	<b>Serial Interface I</b>	
	Typ	RS 232 C; RS 422; RS 485 oder Current loop
	Baudrate	110; 150; 300; 600; 1200; 2400; 4800; 9600; 19200; 38400
	Datenformat	7 bit <sup>1)</sup> / 8 bit
	Parity bit	even, odd, mark, space, no
<b>Voltage supply</b>	Safety	acc. to EN 61010-1:2001 CAT III > 150 V ≤ 300 V pollution degree 2
	DC	10 V ... 19 V ca. 20 VA <sup>2)</sup>  19 V ... 36 V ca. 18 VA <sup>2)</sup>
	AC	85 V ... 265 V , 45 - 65 Hz, ca. 15 W switched-mode power supply
<b>Ambient conditions</b>	Storage temperature range	-20 °C bis +60 °C
	Operating temperature range	0 °C bis +45 °C
	Climate	relative humidity < 80 % up to 31 °C
<b>Standards</b>	Protection type	acc. to EN 60529/VDE 0470
	housing	IP 50
	terminals	IP 00
	Insulation group	C acc. to VDE 0110
	Mech. strength	acc. to IEC 1010
	EMC	
	Emission	EN 55011, Klasse A EN55022, Klasse B
Susceptibility	EN 61000-4-2 B EN 61000-4-3 A EN 61000-4-4 B	

**CE**

1) With 7 bit no parity, the sender must be set to 2 stop bit.  
2) Starting current approx. 1,2 A (10 V ... 19 V) or approx. 0,8 A (19 V ... 36 V).  
This values can be used to rate external fuse.

**Connections**

Voltage supply	Screw type/terminals fixed: 0,2 to 4 mm <sup>2</sup> flexible: 0,2 to 2,5 mm <sup>2</sup> AWG: 24 to 12
Interface I	9pin D-Sub socket
Interface II	9 pin D-Sub socket or USB-B socket
Connection for paper reroll mechanism	4pin MASCON, MLAS
Connection for Alarm relay output	Screw type/terminal fixed: 0,2 to 4 mm <sup>2</sup> flexible: 0,2 to 2,5 mm <sup>2</sup> AWG: 24 to 12 normally open 50 V AC, 2 A 30 V DC, 2 A

**Miscellaneous**

Dimensions (W x H x D)	144 x 72 x 159 mm
Switchboard mounting	screws against rear side of switchboard
Internal fuse ( on power supply board)	12V DC : T 3,15 A 24V DC : T 2 A 110V - 230V AC : T 2 A

**This operating manual applies to software version  
11/03 and higher**

## 2.2. Version E

### Serial Interface II

Type	RS 232 C oder RS 485 <sup>1)</sup> Profibus oder USB
Baudrate	110: 150; 300; 600; 1200; 2400; 4800; 9600; 19200; 38400
Datenformat	7 bit <sup>2)</sup> / 8 bit
Parity bit	even, odd, mark, space, no

### Text entry for texts to be stored

separate configuration  
by interface II

### Text memory

Type	CMOS-RAM, battery buffered <sup>3)</sup>
Battery life	10 years typical
Memory size	600 Byte $\hat{=}$ 15 texts

### Internal clock

Typ	CMOS, battery buffered <sup>3)</sup>
Genauigkeit	$\pm 10$ ppm $\hat{=}$ 0,8 sec / day

1) Please specify when ordering; if nothing is specified, RS 232 C is shipped geliefert.

2) With 7 bit no parity, the sender must be set to „2stop bit“ .

3) Lithium battery: 3 V  
type: VARTA CR 2/3 AA Typ 6237  
PANASONIC BR 2/3A 1 P



### Warning !

This product contains a Lithium battery which must not be cut open, incinerated, exposed to temperature above +60 °C or recharged.

Dispose of in accordance with national regulations.

### 3. Design and Installation

#### Design

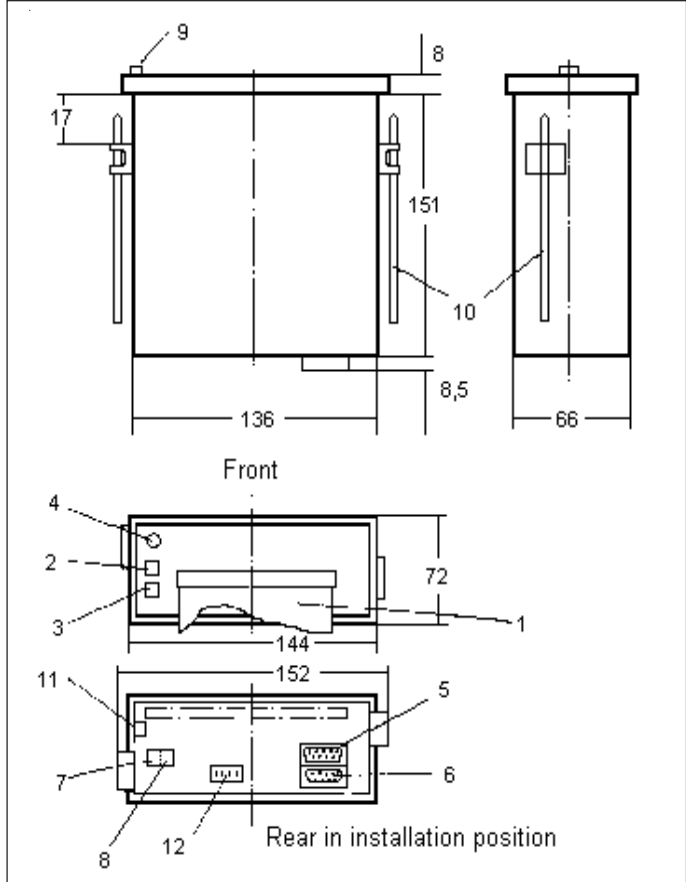

- |   |   |    |  |
|---|---|----|--|
| 1 | Papers and cutting edge                           | 8  | alarm kontakt<br>(paper end only version E)                          |
| 2 | Key: LINE / FEED / Enter                          | 9  | Snap lock  |
| 3 | Key: MENU / Select                                | 10 | Mounting screws  |
| 4 | Alarm diode (paper end indicator)                 | 11 | Protective conductor<br>connection respectively<br>ground connection |
| 5 | Serial interface<br>Interface II (only version E) | 12 | Connection / paper roroll<br>mechanism IPP-AW                        |
| 6 | Serial interface Interface I                      |    |  |
| 7 | Voltage supply                                    |    |  |



Make sure that the unit is properly mounted before connection and power on.

## Installation

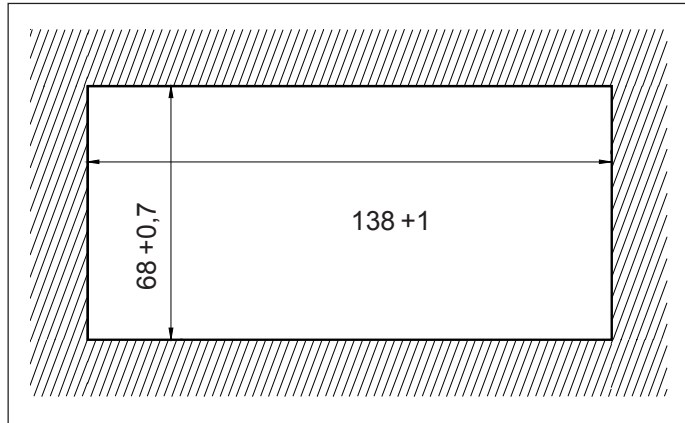

The IPP 144 - 40 G fits into a DIN standard panel cut out. It is inserted into the switchboard opening from the front side and is fixed against the switchboard rear using mounting screws. The switchboard thickness must not exceed 12 mm.

## 4. Connection

### 4.1. Pin assignments

#### Pin assignment

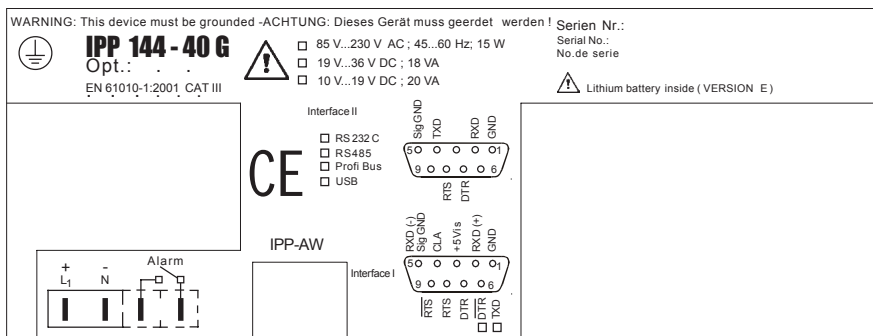

Please follow the instruction on the pin assignment.  
 Dispose of in accordance with national regulations, especially the supply power connection.

# Serial Interface I

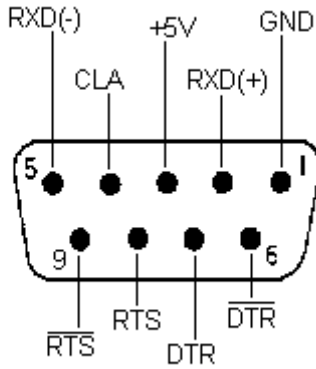

Pin	Signal	
1	GND	Ground (shield)
2	RXD (+)	Receive data
3	+5 V	Output +5 V / 20 mA
4	CLA	
5	RXD (-)	Signal ground
6	$\overline{\text{DTR}}$	Open collector; activ if DTR is +9 V
7	DTR	(Data Terminal Ready) +9 V: ready to receive -9 V: not ready to receive
8	RTS	(Request To Send) +9 V: empfangsbereit -9 V: nicht empfangsbereit (text buffer is full)
9	$\overline{\text{RTS}}$	Open Collector; activ if RTS is +9 V

The serial interface I has been designed to allow the implementation of all widely used interfaces: RS 232 C; RS 422; RS 485 and Current loop. See chapter 4.3.: Connecting diagram

**Serial  
Interface II  
(only  
IPP 144 -40 GE)**

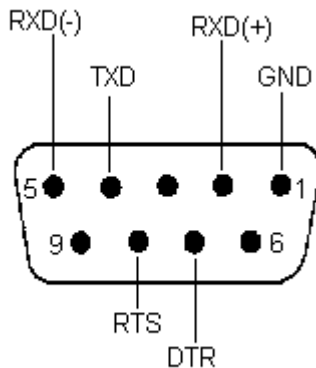

Pin	Signal	
1	GND	Ground (shield)
2	RXD (+)	Receive data
3	n.c.	
4	TXD	Transmit data
5	RXD (-)	Signal ground
6	n.c.	
7	DTR	(Data Terminal Ready) +9 V: ready to receive -9 V: not ready to receive
8	RTS	(Request To Send) +9 V: ready to receive -9 V: not ready to receive
9	n.c.	

this interface can optionally be operated under hardware handshake (DTR, RTS) or software handshake (XON / XOFF - Protocol). this does not require special settings.

See chapter 4.3.: Connecting diagram

## 4.2. Interface selection (Interface I)

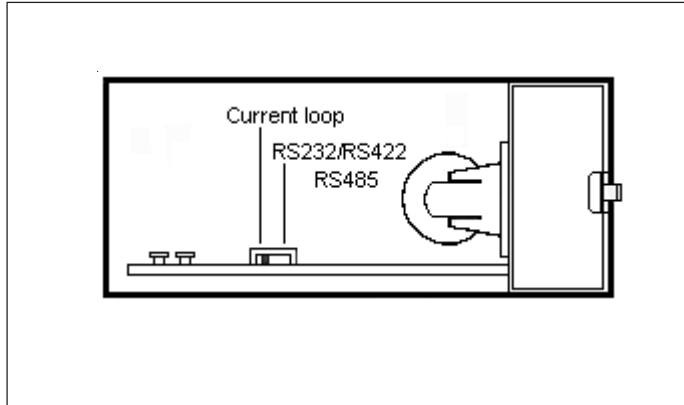

Slide snap lock to the right hand side, swivel front door out. Now you can see the switch S 101 on the printed circuit board.

- For RS 232 C, RS 422 and RS 485 set switch S 101 to the **left** hand side.
- For Current loop, set switch S 101 to the **right** hand side.

### **IMPORTANT:**

This switching only applies to interface I.

If the printer is connected to the sender device (e.g. to a PLC), the interfaces must be adjusted to those at the sender device.

see chapter 6.2 which describes the setting of the baud rate, data format, stop bit and parity bit.

### 4.3. Connecting diagram

#### Interface I

Set slider switch S 101 to the left hand side !  
(see „Interface selection“ 4.2.)

RS 232 C

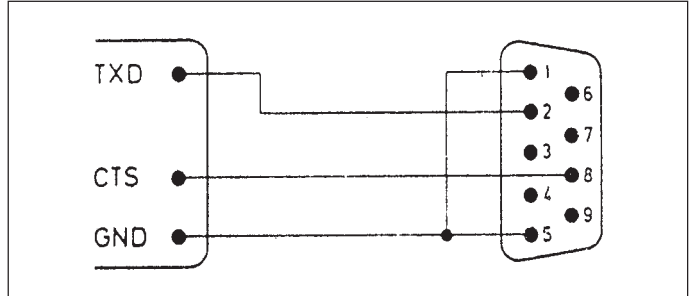

RS 422

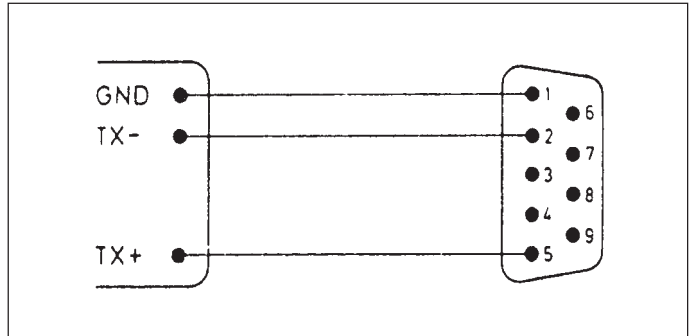

RS 485

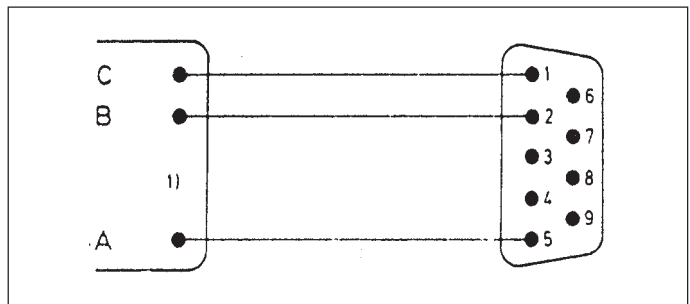

Sender

IPP 144

1) See explanation on page 17

## Current loop

Set slider switch S 101 to the right hand side !  
(see „Interface selection“ 4.2.)

Sender **active**,  
IPP 144 - 40 G  
**passive**

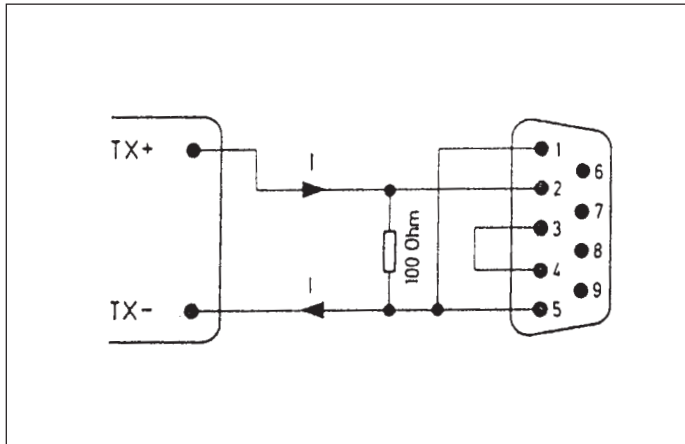

Sender active

IPP 144-40G passive

Sender passive

IPP 144-40G active

Sender **passive**  
IPP 144 - 40 G  
**active**

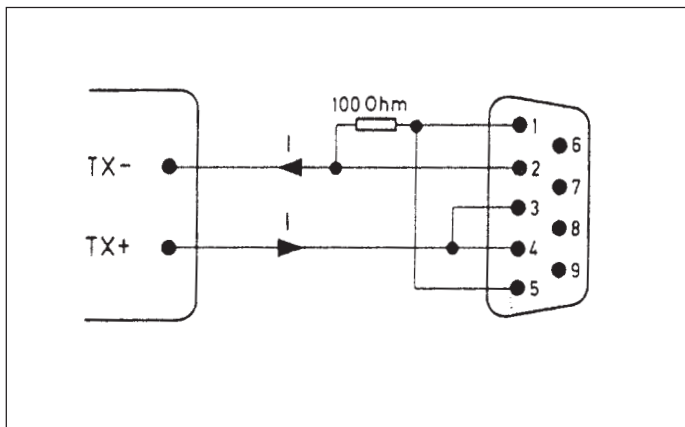

„I“ identifies the direction in which the current flows (20 mA)

## Interface II

### RS 232 C

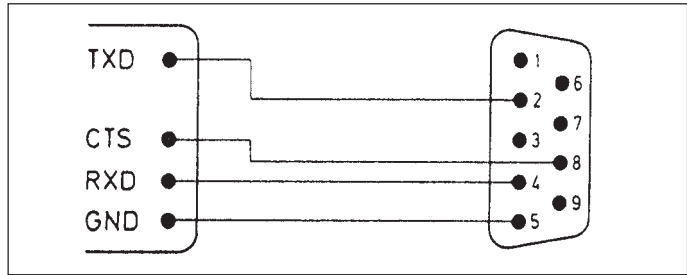

### RS 485 (Option)

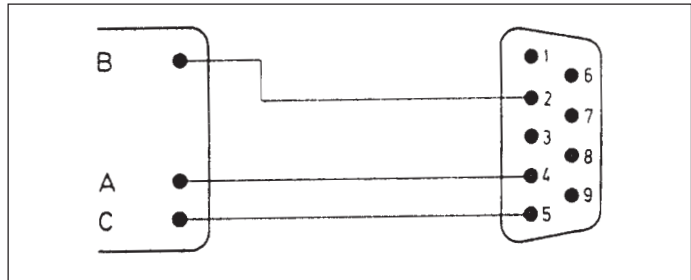

### Profibus (Option)

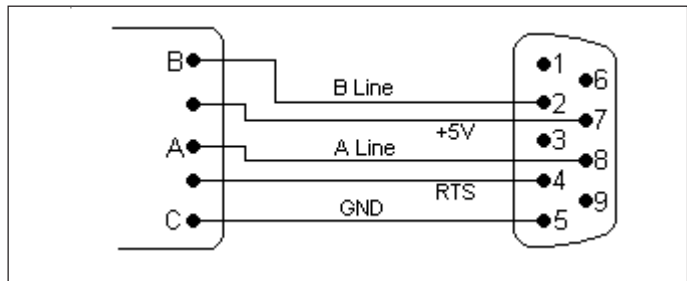

Sender / receiver

IPP 144

- 1) Explanation concerning the signal names under RS 485. The names A, B, C correspond to the EIA 485 - Standard: inactive or logical „1“: A > B  
logical „0“: B > A  
If an interface does not comply with that standard, the connections of A and B must be interchanged.

### USB (Option)

Standard USB chassis socket type B



- pin 1 +5V
- pin 2 USBDM
- pin 3 USBDP
- pin 4 GND

# 5. Operation

## 5.1. Operating Controls

The numbers with the operating controls refer to the diagrams in chapter 3.

**LED  
„Alarm“  
(4)**

If this LED is lit, the printer has run out of paper. Insert a new paper roll; see section 5.2. „Replacing the Paper Roll“.

**LINE FEED /  
ENTER  
(2)**

This key has two functions:

- **LINE FEED:**  
During operation used for manual paper feed.
- In the menu program it is used to accept and save the parameters selected via „Select“.

**MENU /  
SELECT  
(3)**

This key has two functions:

- **MENU:**  
If during operation this key is pressed continuously for more than 3s, the printer switches to menu program mode in which device parameters are printed out and can be modified.
- **Select:**  
Within the menu program it is used for selecting the device parameters.

**Paper cutting  
edge  
(1)**

In order to tear off the paper, pull the paper quickly sideways and up.

**Snap lock  
(9)**

Push this to the right hand side to open the front panel in order to be able to replace the paper roll or to set the slider switch S 101 which is used to set the desired interface (see chapter 4.2. „Interface selection“) or to set the RESET switch S 102.

## Locking the Menu / Select key

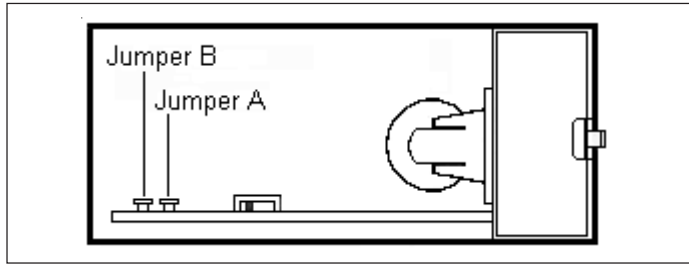

If the jumper B is connected, the „MENU / SELECT“ key is locked; menu parameters can neither be printed or modified.

In order to print or modify parameters:  
remove **jumper B** !

## Write protection (only for IPP144-40GE)

If the jumper A is connected, no texts can be written into the text memory; date and time cannot be set either. If an attempt is made anyway, the printer issues a message:

**! ATTENTION ! - MEMORY LOCKED PLEASE REMOVE JUMPER A AND PRESS „ENTER“**

In order to enable the text save and date/ time setting function:  
remove **jumper A** !

## RESET -key

In order to set the key S102, the printer will be reseted in the standby mode. The menu parameters will not to be changed.

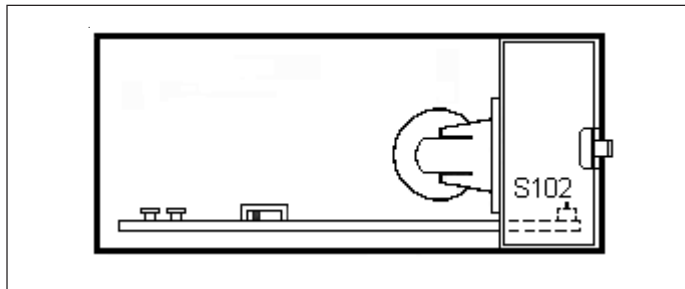

## 5.2. Replacing the Paper Roll

Proceed as described below:

1. Devices with a.c. power supply must be powered off.



**Warning: Dangerous voltage**

is accessible if replacing the paper roll after opening of the front panel !

2. Push the snap lock to the right hand side and open the front panel.
3. Tilt the wire frame upwards; remove the old paper roll.
4. Insert new paper roll; make sure it rotates clockwise during printing (see left side of the figure).
5. Cut the beginning of the paper approx. 1 cm, to get a clean straight edge (see right side of the figure). Insert paper inlet from the bottom as shown in the above diagram.
6. Press the „LINE FEED / ENTER“ key until the paper appears at cutting edge.
7. If you have fed too much paper, carefully rewind the roll. push the wire frame back over the roll.
8. Close the front panel (snap lock must lock). The Alarm LED extinguishes and the printer is ready.

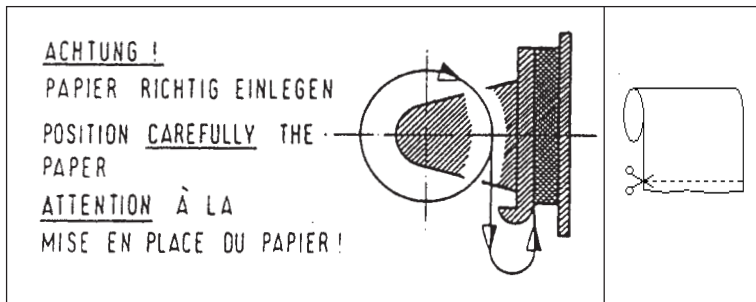

### 5.3. Menu Program

All functions of the IPP 1444 are set via menu program using the „ENTER“ and „SELECT“ keys and are saved when the user quits the program.

From then the IPP 144 automatically uses these parameters.

The print format for the printout of the parameters is always NORMAL with the character set 48 character per line. The printout of the parameters can be read during printing.

The possible settings are explained in chapter 6.

**Entering  
the menu  
program**

Press the „MENU / SELECT“ key for approx. 3 s .

The IPP 144 reacts by printing

„ACTUAL PARAMETERS ? PRESS ENTER“

**Print current  
parameter**

Press the „ENTER“ key,

the IPP 144 prints the currently set parameters.

The final printout

„CHANGE PARAMETERS ?“

## The menu program „Change Parameters“

Press „ENTER“ and „SELECT“ simultaneously for approx. 4 s ; the IPP 144 brings up the first function which can be modified (see changing parameters).

The menu program „Change Parameters“ can be called in one of two ways:

- **Without** prior printing of the current parameters:  
Press both keys following „ACTUAL PARAMETERS ? ...“.
- **With** prior printing of the current parameters:  
Press both keys following „CHANGE PARAMETERS ?“.

## Quitting the menu program

The program is terminated by simultaneously pressing „ENTER“ and „SELECT“ .  
Following the printout  
„ END “  
  
all modified functions are saved.

If there are no keys pressed over a period of approximately 2 minutes, the program is terminated automatically and any **modifications** made **are not saved**.

## Changing parameters

The IPP 144 prints one of the changeable parameter.

- Press „ENTER“ to accept the parameter and to move to the next function.
- Press „SELECT“ to display the next parameter option.

Example:

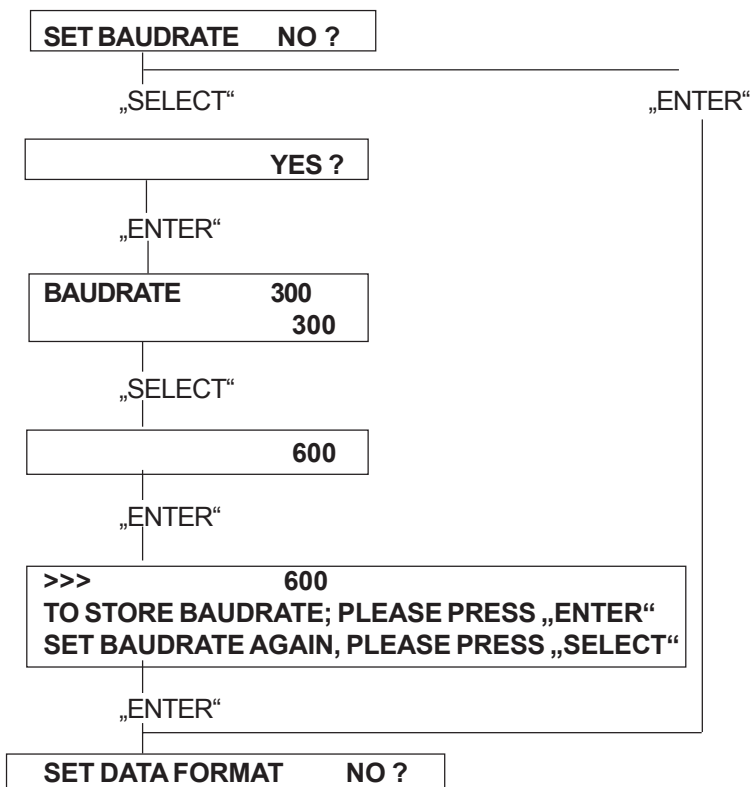

In case is saved!

1: Baudrate 600 (Baud)

2: Baudrate 300 (Baud)

## 6. Adjustment

### 6.1. General Functions

The various functions and device parameters are selected and set via the menu program (see chapter 5.3.) te appendix contains a summary.

#### PRINT FORMAT

- **NORMAL:** The printout can be read during printing, the last print line is at the top.
- **INVERTED:** The printout is made top down, the last print line is at the bottom. In case the printout is in the proper order after the paper as been torn off.

Print formats can be switched via the serial interface (see appendix „additional control characters“), if the input buffer is empty!

- **90-degree rotation:** It is possible to set the printing with 90-degree right or left rotation. This function can not set via the menu program but via control commands (see section 8.3. „Details of Printer Control Commands“).

<b>CHARACTER/ LINE</b>	48:	48 character per line = standard character width
	24:	24 character per line
	16:	16 character per line
	8:	8 character per line

The character width can be switched via the serial interface (at the beginning of a line and only if the input buffer is empty).

#### CHARACTER SET

Available character sets are:  
ASCII, GERMAN, FRENCH, SWEDISH/FINNISH (S/SF),  
DANISH, NORWEGIAN, SPANISH, UK (English) and  
CYRILLIC.

Character sets see appendix 8.2. „Character Sets“ !

<b>INTERFACE</b>	<b>SERIAL:</b> This sets the printer for data transmission via serial interface.
	<b>EMUL.EPSON LQ580 (only version E):</b> This sets the printer for data transmission via EPSON LQ580 protocol.
	<b>EMUL.TALLY T2024 (only version E):</b> This sets the printer for data transmission via TALLY T2024 protocol.
<b>PRINT INTERVAL</b>	The printing of measuring values can be carried out under internal timer control. Setting range: 10 s ... 24 h in steps of 10 s.
	The interval of starts <b>after</b> the printing of the line received last.
	<input type="checkbox"/> For more information see chapter 7.3. „Handshake Messages“ !

## 6.2. Serial Interfaces

<b>BAUDRATE</b>	There are ten baud rates available:  110; 150; 300; 600; 1200; 2400; 4800; 9600; 19200 and 38400 Baud.
<b>DATA FORMAT</b>	There are two formats available:  7 - bit- or 8 - bit - transmission, 1 start bit / ... / parity / 1 stop bit.  <b>Attention:</b> With 7 bit no parity, the sender must be set to 2 stop bits!
<b>PARITY</b>	There are five options available:  Even; Odd; Mark; Space; No parity. There is no check made.

## **PRINTER ADDRESS**

Each printer IPP 144 - 40 G / IPP 144 - 40 GE can be addressed. This allows the concurrent supply of different data to several printers via one data line.

Up to 31 printers may be called from one sender (e.g. a PLC). The respective address is set in the menu program.

for more information see chapter 7.2. „Addressing“ !

## **6.3. Version E (IPP 144 - 40 GE)**

### **6.3.1. Text Entry**

Text can only be entered via interface II.

The maximum text length is 40 characters; if the text length exceed 40 characters only the first 40 characters are saved.

Text may be input via any device capable of sending ASCII characters, i.e. programming devices, terminals, keyboards or personal computers.

The text entry program is called via „CHANGE PARAMETERS“ (see chapter 5.3.) and „TEXT INPUT YES?“.

Differences between the modes „EDIT“ and „FILE“:

- FILE: There is a device available (PC etc.) which has its separate editing software (PC - Tools, WORD etc.) which can be used to modify the text prior to the transmission. The transmission includes the entire file and all texts.
  
- EDIT: There is a keyboard or a terminal available; modifications of the text are made using the <„BS“> (Backspace) key or the arrow keys. Any text entered is immediately printed for checking purposes.

**Entry  
formats**

FILE mode:

```
Text number <CR> Text <CR>
```

This sequence may be continued as required..

No. <CR> Text <CR> Nr. <CR> Text <CR>.

EDIT mode:

Each text number entry is preceded by the <Ctrl A> character:

```
<Ctrl A> Nr. <CR> Text <CR>
```

If < Ctrl A > is omitted, all folowing characters are ignored.

The text number may contain up to 3 characters, e.g. 5 , 05 or 005.

<CR> may be: <CR> by itself or <CR> + <LF>.  
<LF> by itself is not accepted.

**Error  
messages**

ERROR Text - No. -

The entered text number is to high (> 15) or is incorrect in another way.

MISSING Text - No. -

<Ctrl A> was immediately followed by <CR> .

ERROR TEXT -

For blank texts, press the „SPACE“ - key once. <CR> is not accepted on its own.

TRANSMISSION ERROR (File mode) -

Transmission error - send file once more.

If this message occurs repeatedly, check the entry format, reduce the baud rate of the printer and input device (recommended baud rate is 300 baud).

**Terminating  
the text entry**

In EDIT mode: <ESC>  
In FILE mode: <Ctrl Z> or press printer „ENTER“ key.

The message is displayed:

```
PRINT ALL COMMENTS      NO ?
```

Valid options are YES and NO.  
If YES is entered, all texts are printed once more in the order specified by their text numbers.

If NO is entered or after the printout has been completed, another message appears:

```
TO END TEXT - INPUT, PLEASE PRESS „ENTER“  
  
TO REPEAT TEXT - INPUT, PRESS „SELECT“
```

So: To terminate the text entry, press „ENTER“.  
to repeat, press „SELECT“.

If „ENTER“ is pressed, the message appears:

```
*** END OF TEXT - INPUT ***
```

**Adding,  
overwriting  
texts**

If during text entry a text number which has been allocated before is selected, the old text is overwritten with the new text.

! Unselected text numbers are not deleted !

**Deleting  
texts**

Deleting certain texts:

<Ctrl A> No. <CR> <DEL> <CR> (Edit)  
or No. <CR> <DEL> <CR> (File)

<DEL> is the ASCII - Code „7F“  
or the „DELETE“ key („Edit - Modus“).

**Reserving  
space for  
measured  
variables**

In order to be able to insert measured value (variables) into text afterwards, the location within the text must be marked using „Ctrl V“, which reserves 6 spaces into which any characters may be entered, since they are overwritten at a later time anyway; they are merely wildcards.

### Example:

Entry:

```
TEMPERATURE <Ctrl V> XXXXX °C <CR>
```

<Ctrl> counts as one digit, so you only have to enter 5 wildcard characters.

The printout would look like this:

```
TEMPERATURE 263,45 °C.
```

### Creating a text block

A text block is created by combining several texts.

A text block can be printed in a single call.

To achieve this, place the beginning and the end of the text in brackets at entry time. Use the control characters:

Ctrl X = opening bracket

Ctrl Y = closing bracket

So:

- In EDIT mode:
  - <Ctrl A> <Ctrl X> Text - No. <CR> Text <CR>
  - <Ctrl A> Text - No. <CR> Text <CR>
  - 
  - 
  - 
  - <Ctrl A> <Ctrl Y> Text - Nr. <CR> Text <CR>
- In FILE mode:
  - <Ctrl X> Text - No. <CR>Text <CR>
  - Text - No. <CR> Text <CR>
  - 
  - 
  - 
  - <Ctrl Y> Text - No. <CR> Text <CR>

The texts within a text block must have **continuous** numbers !

To delete text within a text block without creating a blank line, the text numbers following the deleted line must be decreased by 1 to move them forward.

This is not done automatically but has to be entered manually.

**Call a text block**

refer to page 37 / 38 and 60

### 6.3.2. Date / Time

**Date entry**

Date and time are factory set. In order to modify these values the menu program must be called and the following message must be displayed:

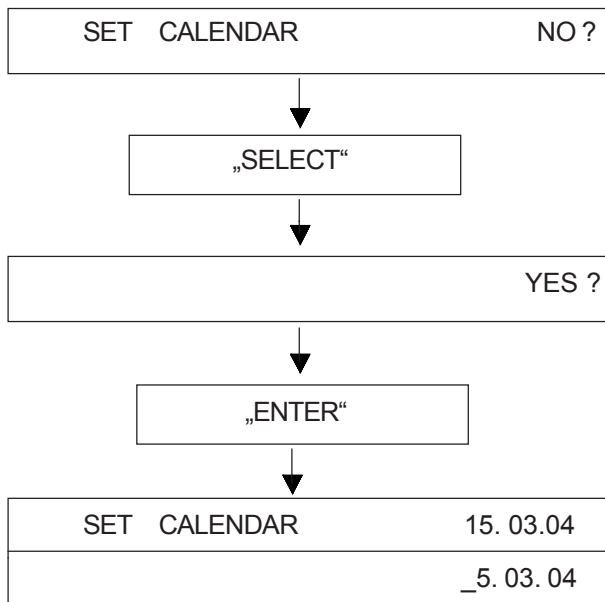

The printed cursor to the left of the 5 indicates that this position can be modified; in our example this is the decimal digit of the day. The „Select“ key is used to print the possible values successively; in our example this is 0, 1, 2 and 3, To accept the value press „Enter“; the cursor jumps to the next position to the right ... etc.

>>>	24. 03. 04
-----	------------

Eventually, the current date is printed.

**Note:**

<p>Incorrect entries, e.g. day 33 of a month, will not be accepted by the printer. Instead, it starts over at the base value 00.</p>
--

**Setting the time**

The time is set like the date. After the current date has been printed, the following line appears:

SET TIME	NO ?
	<ul style="list-style-type: none"> <li>▪</li> <li>▪ Hour</li> <li>▪</li> </ul>
	<div style="display: flex; justify-content: space-around; width: 100%;"> <div style="text-align: center;">Minute</div> <div style="text-align: center;">Second</div> </div>
SET TIME	12 : 31 : 33
	_2 : 31 : 00

If the time is modified, the seconds are automatically set to zero.

If the time has been entered and „Enter“ has been pressed, the following is displayed:

>>>	22 : 31 : 00
TO STORE TIME; PLEASE PRESS „ENTER“	
SET TIME AGAIN; PLEASE PRESS „SELECT“	

SO: if time has been entered correctly, press „Enter“. If the time has been entered incorrectly, repeat the entry by pressing „Select“.

## Set Summer Winter Time Mode

Set one hour plus or minus for Summer/ Winter Time Mode following is displayed:

CHANGE TIME W<->S	NO ?
-------------------	------

If it has been entered „YES“, follow selections are displayed:

„W ---> S (+1 h)“  
„S ---> W (-1 h)“

After setting time the current time will be printed. Press „ENTER“ to store time or press „SELECT“ to set time again.

It means:

W...Winter Time  
S...Summer Time

## 7. Functional Discription

### 7.1. Start Printing

To start the printing, the IPP 144-40 G expects only the character  
<CR> Carriage return, Enter

#### **Hinweis:**

<LF> allein hat by itself has **no** effect combined with other control characters (calling text, send clock, start print interval -see following sections).

If there characters are transmitted **without** a print triggering character, the IPP 144 - 40 G prints them after approx. 3 seconds.

Other widely used print trigger characters such as <FF> Form feed are ignored.

## 7.2. Adressierung

Each IPP 144 - 40 G / IPP 144 - 40 GE printer is addressable. Thus, several printers can be supplied with different data via one data line.

Up to 31 printers can be connected by one sender device (e.g. a PLC). The respective address is set in the menu program.

### Note:

- Standard interface RS 232 only permits 1 sender / 1 receiver; Do not connect more than 4 IPP's as receivers.
- Only interface RS 485 allows up to 32 receivers !

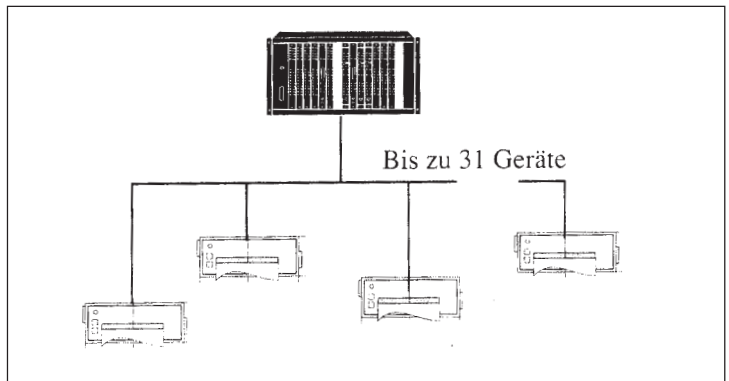

Address / ASCII character assignment example:

Address	Address in Protocol (HEX)	corresponding ASCII - character
0	-	without addressing
1	31	1
▪	▪	▪
▪	▪	▪
▪	▪	▪
30	4 E	N
31	4 F	O

**Protocol & Text**

The addressing protocol is:

```
<Ctrl E> address <Ctrl E> characters ...<CR> <Ctrl D>
A text of more than one line is possible.
```

( <Ctrl E>, <Ctrl D>, see appendix).

A transmission is only accepted if the sequence <Ctrl E> address <Ctrl E> is used !

e.g. print date/time/text:

```
<Ctrl E> address <Ctrl E> <Ctrl \> <CR> characters...
<CR> <Ctrl D>
```

### 7.3. Handshake Messages Serial Interface

**RTS / DTR**

These lines indicate the printer status to sender; DTR (device is on) is rather insignificant and is in general not used.

RTS high (+9 V) indicates: printer is ready to receive.  
RTS low (-9 V) indicates: printer is not ready to receive.

The reasons for printer not ready could be:

- Out of paper
- Print interval running
- Buffer is full
- Change menu

RTS / DTR are only used by the RS 232 C interface and can be used for interface I and II.

**Print interval (serial)**

During the preset wait delay the interface is **not ready to receive**. After expiry of the wait delay the RTS signal (or XON) becomes active again and requests the subsequent transmission.

The next interval begins upon receiving of <CR> or <CR + LF>. <LF> on its own is not accepted.

## XON / XOFF

The report functions „Printer read/not ready“ are handled by this protocol if no handshake lines are connected (RS 232 C, RS 422 or RS 485).

This function only applies to the E version, interface II.

XON is transmitted if the IPP 144-40 GE is ready to receive.

XOFF is transmitted if the IPP 144-40 GE is not ready to receive (see above).

### Note:

If the IPP 144-40 GE is not ready to receive, it transmits this character just once, not continuously.

No adjustments have to be made, this protocol always runs parallel to the hardware handshake.

### Improved handshaking for pre-stored texts

After receiving the control command <CR> the printer now sets RTS at „BUSY“ or the signal XOFF is transmitted. When the printing of pre-stored text is complete, RTS is reset or the signal XON is transmitted.

This handshake can be used to control the data transmission and prevent rapid text calls being lost or overwritten.

### Note:

**Without Handshake** the following can occur, if the text calls are sent in too quickly:

Data input:

<Ctrl C> 1 <CR> <Ctrl C> 2 <CR> <Ctrl C> 3 <CR>

Actual Print-out:

Machine No. 3	pre-stored Text No. 1
2	just „2“ printed, Text No. 2 missing
3	just „3“ printed, Text No. 3 missing

**With Handshake**, provided RTS (or XON/XOFF protocol) is used to control the data transmitter:

Data input:

<Ctrl C> 1 <CR> <Ctrl C> 2 <CR> <Ctrl C> 3 <CR>

Actual Print-out:

Machine No. 3	pre-stored Text No. 1
Automatic mode	pre-stored Text No. 2
Status NORMAL	pre-stored Text No. 3

## 7.4. Text Output (E-Version)

### 7.4.1. Fixed Texts

#### Calling via serial interface

In order to th print text, the printer must receive a transmission with the following format:

< Ctrl C >    text number    < CR >
-------------------------------------

The printer looks up the stored text related with that number and prints it.

If there is no such text, nothing is printed.

Refer to „Automatic text insert mode“,  
page 37 / 38.

#### Important notes:

- <LF> on its own does not start the printing !
- Between several text calls in a row there has to be a gap of least 2 seconds to make sure no text is skipped during printing !
- Several text calls using <Ctrl C> and „normal“ transmissions must not be combined !
- Combination of text and Date / time (protocol) see chapter 7.5. !

The call for a printer with an address:

<Ctrl E> Adr. <Ctrl E> <Ctrl C> Nr. <CR> <Ctrl D>
---

Precede the call with the address (see chapter 7.2.).

## 7.4.2. „Automatic Text Insert Mode

It is now possible to use the Ctrl C > Text No. < CR > method (via the serial interface) to call and insert available data into a pre-stored text with Automatic Text Insert mode.

This mode is selected in the set up menu, as follows:

* * * END OF TEXT INPUT * * *		
TO REPEAT TEXT-INPUT, PRESS		„SELECT“
TO END TEXT-INPUT, PLEASE PRESS		„ENTER“
	YES?	
AUTOM. TEXT INSERT	NO?	
PRINT ALL COMMENTS	NO?	

**Yes** means that the IPP 144-40 GE will insert blocks of variables into one, or more, pre-stored texts.

It is not necessary, and indeed possible, to call the texts individually.

**No** means normal operation as before

### How does it operate:

Each block of variable data is marked by <CR>.

The IPP 144-40 GE takes and holds this data.

After the last <CR> is received it waits about 2 seconds and counts the number of <CR> markers it has received.

It then searches its text file, starting at Text No. 1, and prints out **that number** of pre-stored texts where variable fields have been reserved and inserts the variable data in sequence.

During the search, any texts **without variable fields** that it finds before, or amongst, texts in the file with variable fields are also printed.

When the printing is complete, the IPP 144-40 GE resets itself and is ready again at Text No. 1.

For examples refer to page 60.

### General comments:

- Each message can now contain up to 40 ASCII characters in a variable field. During text programming <Ctrl V> automatically reserves 6 spaces and during printing variable data will be inserted from this point. Therefore, the pre-stored text should have adequate spaces to accept the data to be printed. The data will overwrite stored text if there are not enough spaces.
- It is not necessary to mark a „text block“ with <Ctrl X> <Ctrl Y> during programming.
- The „print interval“ function cannot be combined with this mode.
- While this mode is selected the normal <Ctrl C> Text No. <CR> method to print individual pre-stored texts does not operate. The two modes cannot be mixed.
- Since there is a maxima of 15 pre-stored texts, any input data which exceeds this limit will be ignored.

## 7.5. Date / Time Output (E - Version)

### Output

Date and time may be transmitted via the serial interface II

Request:

< Ctrl W > < CR >

Addressed:

<Ctrl E> Adr. <Ctrl E> <Ctrl W> <CR> <Ctrl D>

Der IPP 144 returns date / time in the format:

< CR > < LF >  
15.03.04            17:03:24  
< CR > < LF >

During the transmission, nothing can be received (RTS = LOW).

**Serial protocol**

The IPP 144 is capable of printing date and time together with measured values or text as a protocol. In this case, date and time precede the printout.

There are two options available:  
Each transmission is preceded with the date/time (always).  
Date and time only precede the transmission if control command has been received.

this optional feature is selected in the menu program under:

**Print date/time „always“**

PRINT DATE / TIME	HEADLINE
-------------------	----------

Each transmission is preceded with the date/time (always).

For several messages in a row (i.e. the IPP 144 is still printing), the date & time is printed once only at the beginning of the transmission.

e.g.:

```
15.03.04      16:57:30
Oil temperature 367,5 °C
Oil pressure o.k.
Boiler 1
```

Pause >

```
15.03.04      16:58:59
Boiler 2      still active
Temperature   258,6 °C
```

**Print date/time with a received control command**

PRINT DATE / TIME	CTRL „ \ „
-------------------	------------

Date and time only precede the transmission if the character <Ctrl \> has been received.

# 8. Appendix

## 8.1. Menu program / Complete Selection

Basic version

```

SET BAUDRATE          NO ?
                      YES ?
BAUDRATE              19200
                      38400
                      110
                      150
                      300
                      600
                      1200
                      2400
                      4800
                      9600
                      9600
>>>                  9600
SET DATA FORMAT      NO ?
                      YES ?
SET DATA FORMAT      8
                      7
>>>                  7
SET PARITY            NO ?
                      YES ?
SET PARITY            NO PARITY
                      PARITY
                      EVEN
                      ODD
                      MARK
                      SPACE
                      SPACE
>>>                  SPACE
PRINTER ADDRESS       NO ?
                      YES ?
PRINTER ADDRESS       00
                      _0
                      10
                      20
                      30
                      00
                      0_
                      01
                      .
                      .
                      09
                      00
                      00
>>>                  00
SET PRINT FORMAT      NO ?
                      YES
PRINT FORMAT          INVERSE
                      NORMAL
>>>                  NORMAL
  
```

```

SET CHARACTER/LINE    NO ?
                      YES ?
CHARACTER/LINE        48 CHARACTERS
                      48 CHARACTERS
                      24 CHARACTERS
                      16 CHARACTERS
                      8 CHARACTERS
                      8 CHARACTERS
>>>
SET CHARACTER          NO ?
                      YES ?
SET CHARACTER          ASCII
                      GERMAN
                      SWEDISH/FINNISH
                      FRENCH
                      DANISH
                      NORWEGIAN
                      SPANISH
                      UK
                      CYRILLIC
                      ASCII
>>>                  ASCII
SET INTERFACE         NO ?
                      YES ?
SET INTERFACE         SERIAL 1)
>>>                  SERIAL

*** END ***
  
```

1) Basic version Interface set only serial

Version E

```

SET TIME          NO ?
                  YES ?
SET TIME          15:57:26
                  _5:57:00
                  . . .
                  15:4_ :00
>>>              15:48:00
TO STORE TIME, PLEASE PRESS „ENTER“
TO SET TIME AGAIN, PRESS „SELECT“
SET CALENDAR      NO ?
                  YES ?
SET CALENDAR      12.01.03
                  _2.01.03
                  1_ .01.03
                  . . .
                  16.02.0_
>>>              16.02.04
CHANGE TIME W<->S NO ?
                  YES ?
CHANGE TIME W<->S 14:07:14
W --> S (+1h)
S --> W (-1h)
>>>              15:07:14
SET INTERVAL      NO ?
                  YES ?
SET INTERVAL      00 h 00 min 00 sec
                  00 h 00 min _0 sec
                  00 h 0_ min 50 sec
                  00 h _4 min 50 sec
                  0_ h 34 min 50 sec
                  _2 h 34 min 50 sec
>>>              12 h 34 min 50 sec
TEXT-INPUT        NO?
                  ----->
PRINT DATE/TIME   NO?
                  YES?
                  CTRL“^“
                  HEADLINE
    
```

SETTING ACCORDING TO BASIC VERSION

```

SET BAUDRATE
SET DATA FORMAT
SET PARITY
PRINTER ADDRESS
SET PRINT FORMAT
SET CHARACTER/LINE
SET CHARACTER

SET INTERFACE     NO ?
                  YES ?           2)
SET INTERFACE     SERIAL
                  SERIAL
                  EMUL.EPSON LQ580
                  EMUL.TALLY T2024
>>>              EMUL.TALLY T2024

*** END ***
    
```

```

TEXT-INPUT        YES ?
PRINT ALL COMMENTS YES ?      1)
                  NO ?

                  EDIT ?
                  FILE ?

PRINT ALL COMMENTS YES ?      1)
                  NO ?

TO REPEAT TEXT-INPUT, PRESS „SELECT“

                  YES ?
AUTOM. TEXT INSERT NO ?
PRINT ALL COMMENTS NO ?

*** END OF TEXT-INPUT ***
    
```

1) - Printing of all stored texts  
 2) - Selection for Interface II

## 8.2. Character Sets

### Control Character used for Data Transmission

#### General purpose characters

Character	HEX	Significance	Name
Ctrl D	04	End of transmission	EOT
Ctrl E	05	Set address	ENQ
Ctrl J	0A	Line feed	LF
Ctrl M	0D	Carriage return	CR
Ctrl Q	11	Ready to receive	XON
Ctrl S	13	Busy	XOFF

#### Additional characters used by the printer

Ctrl F	06	48 character / line
Ctrl R	12	24 character / line
Ctrl T	14	Inverted printing
Ctrl U	15	Normal printing
Ctrl W	17	transmit request: date / time
Ctrl \	1E	Print: date / time in protocol
Ctrl A	01	Text entry (edit - mode)
Ctrl C	03	Text call
Ctrl X	18	Start of text block
Ctrl Y	19	End of text block
Ctrl V	16	Reserve space for measure variable (6 digits)
Ctrl Z	1A	End of file mode
Ctrl [	1B	End of edit mode (ESC)

#### Charcter set - various languages

The following HEX codes differ from theASCII character set:

Hex-Code	23	24	40	5B	5C	5D	5E	60	7B	7C	7D	7E
ASCII	#	\$	@	[	\	]	^	`	{		}	~
German	#	\$	§	Ä	Ö	Ü	^	`	ä	ö	ü	ß
S / SF	#	⌘	É	Ä	Ö	À	Û	é	ä	ö	à	û
French	#	\$	à	°	ç	§	^	`	é	ù	è	…
Danisch	#	\$	É	Æ	Ø	À	Û	é	æ	ø	à	û
Norwegian	#	⌘	É	Æ	Ø	À	Û	é	æ	ø	à	û
Spanish	#	\$	à	í	Ñ	¿	é	`	□	ñ	ó	ú
English	£	\$	@	[	\	]	^	`	{		}	~

33	!	71	G	109	m	147	ð	185	⌈	222	┌
34	"	72	H	110	n	148	ö	186	⌋	223	└
35	#	73	I	111	o	149	ò	187	⌌	224	α
36	\$	74	J	112	p	150	ô	188	⌍	225	β
37	%	75	K	113	q	151	ù	189	⌎	226	Γ
38	&	76	L	114	r	152	ÿ	190	⌏	227	π
39	'	77	M	115	s	153	Ö	191	⌐	228	Σ
40	(	78	N	116	t	154	Ü	192	⌑	229	σ
41	)	79	O	117	u	155	€	193	⌒	230	τ
42	*	80	P	118	v	156	£	194	⌓	231	μ
43	+	81	Q	119	w	157	¥	195	⌔	232	Φ
44	,	82	R	120	x	158	℞	196	⌕	233	θ
45	-	83	S	121	y	159	f	197	⌖	234	Θ
46	.	84	T	122	z	160	ä	198	⌗	235	Ω
47	/	85	U	123	{	161	í	199	⌘	236	δ
48	0	86	V	124	}	162	ó	200	⌙	237	ω
49	1	87	W	125	~	163	ú	201	⌚	238	∅
50	2	88	X	126	■	164	ñ	202	⌛	239	∈
51	3	89	Y	127	■	165	Ñ	203	⌜	240	∩
52	4	90	Z	128	■	166	ä	204	⌝	241	≡
53	5	91	[	129	■	167	ö	205	⌞	242	±
54	6	92	\	130	■	168	ä	206	⌟	243	≥
55	7	93	]	131	■	169	ä	207	⌠	244	≤
56	8	94	^	132	■	170	ä	208	⌡	245	≠
57	9	95	_	133	■	171	ä	209	⌢	246	I
58	:	96	`	134	■	172	ä	210	⌣	247	÷
59	;	97	a	135	■	173	ç	211	⌤	248	=
60	<	98	b	136	■	174	è	212	⌥	249	.
61	=	99	c	137	■	175	è	213	⌦	250	.
62	>	100	d	138	■	176	è	214	⌧	251	√
63	?	101	e	139	■	177	ï	215	⌨	252	η
64	@	102	f	140	■	178	ï	216	〈	253	²
65	A	103	g	141	■	179	ï	217	〉	254	■
66	B	104	h	142	■	180	Ä	218	⌫	255	□
67	C	105	i	143	■	181	Ä	219	⌬		
68	D	106	j	144	■	182	É	220	⌭		
69	E	107	k	145	■	183	æ	221	⌮		
70	F	108	l	146	■	184	Æ		⌯		

\*) The following characters have been modified as compared to the IBM character set No. 437:

244	F4	"	⌈	"	—▷	"I"
245	F5	"	⌋	"	—▷	"I"
255	FF	"	⌌	"	—▷	"□"

## Character set: ASCII and cyrillic

it means:

1.Column = ASCII / 2. Column = cyrillic / 3. Column = Hexadecimal

		20	@	@	40		Ю	60
!	!	21	А	Ф	41	a	Ф	61
"	"	22	В	И	42	b	и	62
#	#	23	С	С	43	c	с	63
\$	\$	24	Д	В	44	d	в	64
%	%	25	Е	У	45	e	у	65
&	&	26	Ф	А	46	f	а	66
/	ю	27	Г	Ч	47	g	ч	67
(	(	28	Н	П	48	h	п	68
)	)	29	І	Ш	49	i	ш	69
*	ь	2A	Ј	О	4A	j	о	6A
+	+	2B	К	Л	4B	k	л	6B
,	,	2C	Л	Д	4C	l	я	6C
-	-	2D	М	Ё	4D	m	ё	6D
.	.	2E	Н	Т	4E	n	т	6E
/	/	2F	О	Ш	4F	o	щ	6F
0	0	30	Р	З	50	p	э	70
1	1	31	Q	Й	51	q	й	71
2	2	32	R	К	52	r	к	72
3	3	33	S	Ы	53	s	ы	73
4	4	34	T	Е	54	t	е	74
5	5	35	U	Г	55	u	г	75
6	6	36	V	М	56	v	м	76
7	7	37	W	Ц	57	w	ч	77
8	8	38	X	Р	58	x	р	78
9	9	39	Y	Я	59	y	я	79
:	:	3A	Z	Н	5A	z	н	7A
;	;	3B	[	Э	5B	{	э	7B
<	<	3C	\	Ж	5C	`	ж	7C
=	=	3D	]	Х	5D	}	х	7D
>	>	3E	^		5E	~	ó	7E
?	Б	3F	_	ь	5F	■	■	7F

## 8.3. Details of Printer Control Commands

### 8.3.1. Short View of Control Commands

#### Print Character Commands (Section 8.3.2.)

ESC % n    Specifies/clears download character set  
ESC - n    Specifies/clears underline  
ESC V n    Specifies/clears character rotation  
GS ! n     Specifies character size

#### Print Position Commands (Section 8.3.3.)

ESC \$ nL nH    Specifies absolute position  
ESC D            Specifies horizontal tab position

#### Bitmap image Commands (Section 8.3.4.)

ESC \* m nL nH    Specifies column bitmap image  
ESC A\* nL nH    Specifies raster bitmap image  
GS \* x y          Defines download bitmap image  
GS / m            Prints download bitmap image

#### Line Feed Commands (Section 8.3.5.)

ESC 2            Specifies initial line feed  
ESC 3 n          Specifies line feed

#### Barcode Commands (Section 8.3.6.)

GS H n            Selects print position of HRI character  
GS h n            Sets barcode height  
GS w n            Sets width of barcode  
GS k m / GS k m n    Prints barcode

### 8.3.2. Print Character Commands

**Specifies /  
clears  
character  
rotation**

**Command:**        **ESC V n**

<< Code >>

0x1B , 0x56, n (0 ≤ n ≤ 3 , 48 ≤ n ≤ 51 , initial value n=0)

<< Function >>

Specifies or clears character rotation.

The definition of parameters is as follows

n	Function
0, 48	Cancels rotation
1, 49	Specifies 90-degree right rotation
3, 51	Specifies 90-degree left rotation

<< Details >>

Specifies 180-degree rotation (Invers-Print)  
see section 6.1.

Rotated characters are not underlined even if character rotation is specified (ESC !), (ESC -) or (FS -).

If a 90-degree right or left rotation is specified, the vertical and horizontal magnifications of a character specified before the rotation is reversed.

**Specifies /  
clears  
underline**

**Command: ESC - n**

<< Code >>

0x1B , 0x2D, n ( $0 \leq n \leq 2$ ,  $48 \leq n \leq 50$ , initial value n=0)

<< Function >>

Specifies or clears an underline

n	Function
0, 48	Clears underline
1, 49	Sets a 1-dot wide underline and specifies an underline
2, 50	Sets a 2-dots wide underline and specifies an underline

<< Details >>

Rotated characters (ESC V) are not underlined.

If the underlining of characters is cleared with n=0 or n=48, subsequent data are not underlined but the previously set under size is retained. In addition, a one-dot underline is set by default.

The size of an underline is the same for all character sizes as specified.

**Specifies  
character size**

**Command: GS ! n**

<< Code >>

0x1D , 0x21, n

( $0 \leq n \leq 255$ ,  $1 \leq \text{vertical magnification} \leq 8$ ,

$1 \leq \text{horizontal magnification} \leq 8$ , initial value n=0)

<< Function >>

Specifies character size (vertical and horizontal magnification)

Bit	Function	Value	
		0	1
0	vertical magnification	see Table 2	
1			
2			
3			
4	horizontal magnification	see Table 1	
5			
6			
7			

Table 1

bit7	bit6	bit5	bit4	Magnification
0	0	0	0	1 (Std.)
0	0	0	1	2 (horizontal)
0	0	1	0	3
0	0	1	1	4
0	1	0	0	5
0	1	0	1	6
0	1	1	0	7
0	1	1	1	8

Table2

bit3	bit2	bit1	bit0	Magnification
0	0	0	0	1 (Std.)
0	0	0	1	2 (vertical)
0	0	1	0	3
0	0	1	1	4
0	1	0	0	5
0	1	0	1	6
0	1	1	0	7
0	1	1	1	8

<< Details >>

This command is ignored if either a vertical or horizontal magnification is outside the definable range.

In the standard mode, the vertical direction refer to the direction of paper feed, and the horizontal direction the direction right to the direction of paper feed. If characters are 90-degree right or left are specified, the relationship of the vertical and horizontal directions is reversed.

If characters with different vertical magnifications are contained in the same line, they are aligned to the baseline.

**Specifies / clears download character set**

**Command: ESC %n**

<< Code >>

0x1B , 0x25 , n (0≤n≤255 , initial value n=0)

<< Function >>

Specifies or clears a download character set.

Only the lowest bit of n is effective. Download character setting is specified if n=1 and cleared if n=0.

<< Details >>

Automatically specifies the internal character set if the downloading of a character set is cleared.

### 8.3.3. Print Position Commands

**Specifies absolute position**

**Command: ESC \$ nL nH**

<< Code >>

0x1B , 0x24, nL , nH (0 ≤ nL ≤ 255 , 0 ≤ nH ≤ 255)

<< Function >>

Specifies the next print start position as an absolute position based on the left margin position.

The next print start position is (nL + nH x 256) dots away from the left margin position.

<< Details >>

A print start position specified outside the print area is ignored.

**Sets horizontal tab position**

**Command: ESC D n1~ nk NULL**

<< Code >>

0x1B , 0x44 , n<sub>1</sub>~ n<sub>k</sub> (k bites) , 00H (1 ≤ k ≤ 32 , 1 ≤ n ≤ 255)

Selects a tab position every 8 characters (at 9th point , 17th point , 25th point ...), if the setting for character right space = 0.

<< Function >>

Sets horizontal tab positions.

n refers to the number of points to the tab position from the left margin or the start of the line.

k indicates the number of data of horizontal tab positions to be set.

<< Details >>

A tab position to be set is (n x character width) from the left margin or the start of the line. Character width includes the right space of character (ESC SP), and increases in proportion to the horizontal magnification of the character if the magnification is larger than two.

After this command is executed, the previously set horizontal tab positions are cleared.

If n=8 is set for horizontal tab position, the next print start position is moved to the 9th point by (HT: „Horizontal tab“).

The maximum allowable number of horizontal tab positions is 32 (k=32). If this is exceeded, subsequent data is treated as normal data.

Enter n1~nk for specifying tab positions in ascending order and ends the data entering with 00H. If n is equal to or smaller than the previous value, the horizontal tab setting process stops and subsequent data is processed as normal data.

Use (ESC D NULL) to clear all horizontal tab positions. Even if character with is changed after setting horizontal tab positions, the set horizontal tab positions are retained.

### 8.3.4. Bitmap image Commands

**Prints column Command: ESC \*m nL nH d1~ dk  
bitmap image << Code >>**

0x1B, 0x2A, m, nL, nH, d1~dk

where: m=0, 32,  $0 \leq nL \leq 255$ ,  $0 \leq nH \leq 3$ ,  $0 \leq d \leq 255$

<< Function >>

Specifies a bitmap image in mode m for the number of dots specified by nL and nH.

m	Mode	No. of vertical dots	No. of Data (K)
0	8-dot single density	8 dots	$nL+nH \times 256$
1	8-dot double density	8 dots	$nL+nH \times 256$
32	24-dot single density	24 dots	$(nL+nH \times 256) \times 3$
33	24-dot double density	24 dots	$(nL+nH \times 256) \times 3$

<< Details >>

Processes the data after nL as normal data if m is outside the definable range.

nL and nH denote the number of horizontal dots of the bitmap image to be printed, which is  $(nL+nH \times 256)$ .

If bitmap image data exceeding the number of printable dots in a line is entered, the excess data is discarded. d denotes bitmap image data. The bit for the dot to be printed is „1“ and the bit the dot not to be printed is „0“. Returns to normal data processing after bitmap image processing.

Has no effect on print modes (underline, character size) excluding NORMAL.

Prints the entered bitmap image magnified three times in the vertical direction if m=0 or 1 (8-dot mode) is specified and two times in the horizontal direction if m=0 or 32 (single density mode) is specified.

The data format of a bitmap is as follows:

### Bitmap-Data format

Dot	Col.1	Col.2	....	Col.n
1				
:	d1	d4	....	d 3n-2
8				
:	d2	d5	....	d 3n-1
16				
:	d3	d6	....	d 3n
24				
	d 3(n+1)-2	d 3(n+2)-2	....	d 6n-2
	d 3(n+1)-1	d 3(n+2)-1	....	d 6n-1
	d 3(n+1)	d 3(n+2)	....	d 6n

MSB
LSB

**Prints raster bitmap image**    **Command: ESC A\* nL nH d1~ dk**  
 << Code >>

0x1B , 0x41 , 0x2A , nL , nH , d1~dk

where: 0 ≤ nL ≤ 255 , 0 ≤ nH ≤ 255, 0 ≤ d ≤ 255

<< Function >>

Specifies the raster bitmap image specified with  $(nL + nH \times 256)$  lines in the vertical direction.

<< Details >>

This command is effective only if this command is entered at the start position of a line in zthe standard mode.

d refers to bitmap image data. The bit for the dot to be printed is „1“ and the bit for the dot not to be printed is „0“.

The required number of image data per line is as follows depending on the number of heating elements in the head:

dots of heating element	192 dots	288 dots	384 dots	576 dots
No. data per line	24 bytes	36 bytes	48 bytes	72 bytes

The required total number of bitmap image data is  $((nL + nH \times 256) \times \text{no. of data per line})$  bytes.

The format of bitmap data for a printer with n heating elements in the headis as follows:

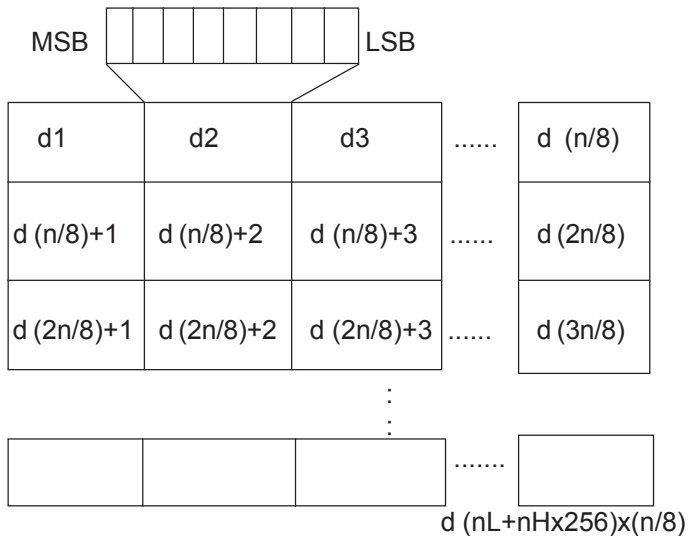

**Defines  
download  
bitmap image**

**Command: GS \* xy [d1] ... [d]x X y X 8**

<< Code >>

0x1D , 0x2A , x , y , [d1] ~ [d]x X y x 8

where:

$0 \leq x \leq 255$

$0 \leq y \leq 48$ , where:  $x \times y \leq 1536$

$0 \leq d \leq 255$

<< Function >>

This command download bitmap image into the font ROM, for example logos. The parameters x und y defin the dimension of the bitmap image.

<< Details >>

Frequent use of this command may cause damage to the option font ROM. It is recommended to use this command no more than 10 time a day.

The number of dots in the horizontal and vertical direction is  $x \times 8$  dots and  $y \times 8$  dots respectively.

x specifies the number of dots in the horizontal direction.

y specifies the number of dots in the vertical direction.

d refers to bitmap image data. The bit for the dot to be printed is „1“ and the bit for the dot not to be printed is „0“.

The relationship between a download bitmap image and print data is as follows:

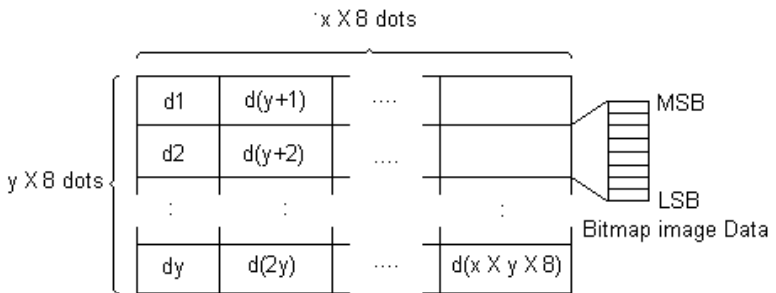

**Print  
download  
bitmap image**

**Command: GS / m**

<< Code >>

0x1D , 0x2F , m ( $0 \leq m \leq 3$  ,  $48 \leq m \leq 51$ )

<< Function >>

Druckt die definierte Download- Bitmap-Grafiken.  
m legt den Druck-Modus fest.

m	Print mode
0, 48	Normal mode
1, 49	Double-with mode
2, 50	Double-height mode
3, 51	Double-height/width mode

<< Detail >>

This command is ignored if download bitmap image data is not defined.

Effective only when no data is contained in print buffer if standard mode is selected.

Has no effect on print modes (underline, character size) excluding NORMAL.

If the number of the defined download bitmap data exceeds the print area, the excess data is not printed.  
the maximum of print width is 72 mm (576 dots per line).

### 8.3.5. Line Feed Commands

**Sets initial  
line feed**

**Command: ESC 2**

<< Code >>

0x1B , 0x32

<< Function >>

Sets the amount of the initial line feed per line to 30 dots.

<< Details >>:

The amount of the initial line feed can be set separately for the standard mode.

**Sets line feed Command: ESC 3n**

<< Code >>

0x1B , 0x33 , n (0≤n≤25 , initial value n=60)

<< Function >>

Sets the amount of line feed per line to n dot.

<< Details >>

Line feed can be set separately for the standard mode.

### 8.3.6. Barcode Commands

**Selects printing position of HRI character**

**Command: GS H n**

<< Code >>

0x1D , 0x48 , n ( $0 \leq n \leq 3$  ,  $48 \leq n \leq 51$  , initial value n=0)

<< Function >>

Selects the print position of HRI characters when printing a barcode.

<< Details >>

HRI refers to Human Readable Interpretation.

The HRI character font for barcode printing is fixed on the FONT A (12x24).

**Sets barcode height**

**Command: GS h n**

<< Code >>

0x1D , 0x68 , n ( $1 \leq n \leq 255$  , initial value n=162)

<< Function >>

Sets barcode height to n dots.

**Sets width of barcode**

**Command: GS w n**

<< Code >>

0 x 1D , 0 x 77 , n ( $2 \leq n \leq 6$  , initial value n=3)

<< Function >>

Specifies barcode width.

n	Module width of multi-level-barcode (dots)	2-level-barcode	
		Thin element width (dots)	Thick element width (dots)
2	2	2	5
3	3	3	9
4	4	4	11
5	5	5	14
6	6	6	18

<< Details >>

The multi-level-barcode refers to the following barcode systems:

- A) UPC-A
- B) UPC-E
- C) JAN13
- D) JAN8
- E) CODE93
- F) CODE128

The 2-level-barcode refers to the following barcode systems:

- A) CODE39
- B) ITF
- C) CODABAR

**Prints  
barcode**

**Command: GS k m d1~ dk NULL/GS k m n d1~ dn**

<< Code >>

0x1D , 0x6B , m , d1~ dk 00H (0≤m≤6 , the definable range of k and d varies with m.)

0x1D , 0x6B , m , n , d1~ dn (65≤m≤73 , the definable range of n and d varies with m.)

<< Function >>

Selects a barcode system and prints barcodes.

In the case of GS k m:

m	Barcode-System	Definable range of k	Definable range of d
0	UPC-A	fixed (11≤k≤ 12)	48≤d≤ 57
1	UPC-E	fixed (11≤k≤ 12)	48≤d≤ 57
2	JAN13 (EAN)	fixed (12≤k≤13)	48≤d≤ 57
3	JAN8 (EAN)	fixed (7≤n≤ 8)	48≤d≤ 57
4	CODE39	variable (1≤ k)	48≤d≤ 57 65≤d≤ 90 32,36,37,43,45,46,47
5	ITF	variable (1≤ k, even number)	48≤d≤ 57
6	CODABAR	variable (1≤ k)	48≤d≤ 57 65≤d≤ 68 36,43,45,46,47,58

In the case of GS k m:

m	Barcode-System	Definable range of k	Definable range of d
65	UPC-A	fixed (11 ≤ n ≤ 12)	48 ≤ d ≤ 57
66	UPC-E	fixed (11 ≤ n ≤ 12)	48 ≤ d ≤ 57
67	JAN13 (EAN)	fixed (12 ≤ n ≤ 13)	48 ≤ d ≤ 57
68	JAN8 (EAN)	fixed (7 ≤ n ≤ 8)	48 ≤ d ≤ 57
69	CODE39	variable (1 ≤ n ≤ 255)	48 ≤ d ≤ 57 65 ≤ d ≤ 90 32,36,37,43,45,46,47
70	ITF	variable (1 ≤ n ≤ 255, even number)	48 ≤ d ≤ 57
71	CODABAR	variable (1 ≤ n ≤ 255)	48 ≤ d ≤ 57 65 ≤ d ≤ 68 36,43,45,46,47,58
72	CODE93	variable (1 ≤ n ≤ 255)	0 ≤ d ≤ 127
73	CODE128	variable (2 ≤ n ≤ 255)	0 ≤ d ≤ 127

<< Details >>

In the case of GS k m:

This command is terminated by the NULL code.

In the case of UPC-A and UPC-E, after 12 bytes of barcode data are entered, the barcode is printed, and subsequent data is processed as normal data.

In the case of JAN-13, after 13 bytes of barcode data are entered, the barcode is printed, and subsequent data is processed as normal data.

In the case of JAN-8, after 8 bytes of barcode data are entered, the barcode is printed, and subsequent data is processed as normal data.

The number of data of an IFT barcode must be an even number. If is an odd number, the last data is ignored.

After the number of input data reaches 255, the processing of the command starts automatically.

In the case of GS k m:

n denotes the number of data. n bytes of subsequent data are processed as barcode data.

If n is outside the definable range, the processing of the command stops, and the subsequent data is processed as normal data.

In the case of standard mode:

If *d* is outside the definable range, only paper feed is executed, and subsequent data is processed as normal data.

If the barcode width exceeds the print area of one line, the barcode is not printed, and only paper feed is executed.

Regardless of the amount of line feed specified by the following commands, the paper is fed by the amount equal to the barcode height (including HRI characters if HRI character print is specified):

\* (ESC 2: "Sets initial line feed")

\* (ESC 3: "sets line feed")

Effective only if no data is contained in the print buffer. If data is contained in print buffer, the data after *m* is processed as normal data.

Moves the print position to the start of the next line after barcode print is completed.

Has no effect on print modes (underline, character size) excluding NORMAL.

## 8.4. Connection Examples for Gossen Müller & Weigert instruments

### 8.4.1. Connection of the IPP 144-40 GE to the DPM-MF for the insertion of measured value into texts

For this configuration You must input the text how shown in the sections 6.3.1 and 7.4.1. and especially the sections 7.4.2. und 8.5. in this manual. The printer receives the measuring values via interface I / RS 232 C (als possible via interface II). To selected the text see section 7.4.2 in this manual. the relevant interface is the interface for which the parameters above to be set in the menu program. The recommended configuration is: 8 data bits, no parity, 1 stop bit, 9600 baud. With 7 bit, no parity, the sender must be set to 2 stop bits.

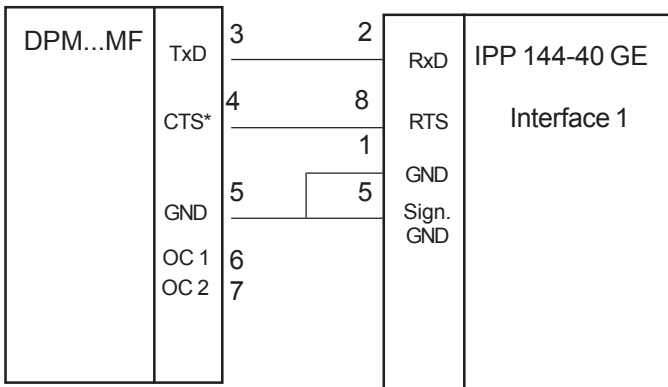

## 8.4.2. Coupling of IPP 144 - 40 G with a DAA message display to print fault message

Messages can be issued by all DAA type B and C versions. (The A version DAA are not capable of outputting data but only of displaying them since there is only one serial interface available which is used to receive data).

The connection of the printer is made via the interface II (RS 232 C) of the DAA. The printout is normally triggered by a control device (e.g. a PLC) with a strobe signal (strobe T) via the terminal strip for control inputs (parallel interface) at the DAA.

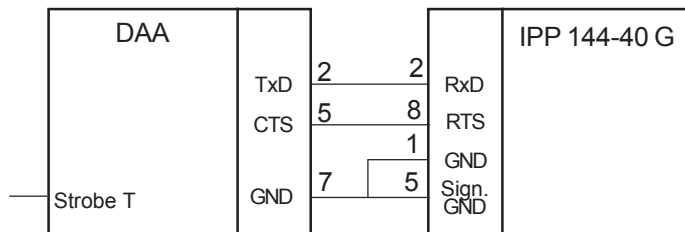

Interface RS - 232 C:

DAA 144 - 120 B: 9 pin D - SUB 9 pin D - SUB

DAA 288 - 129 B: 25 pin D - SUB

DAA 288 - 240 B, C: 25 pin D - SUB

The required connection cable is available as an accessory.

## 8.5. Examples for Automatic text Insert mode

**Example 1:**  
 Consignment  
 print-out, with  
 time & date,  
 marks and  
 weights

Data input:

10:15:33 15/10/03 <CR>1<CR> 123 <CR> 1 <CR> 1027<CR> 997 <CR> 30 <CR>

**Actual Print-out:**

10:15:33	15/10/03
Product Ref:	123
Operator No:	1
Gross:	1027 kg
Nett:	997 kg
Tare:	30 kg

**Pre-stored texts**

(„\*“ = spaces reserved for variable data)

1	*****
2	Product Ref: *****
3	Operator No: *****
4	Gross: *****
5	Nett: *****
6	Tare: *****

Six block of data are inserted and printed in sequence.

**Example 2:**  
 Quality test  
 print-out, with  
 several  
 measured  
 value

In this example, the IPP.E automatically adds date & time from its own real-time clock using the „PRINT DATE / TIME-HEADLINE“ menu option. Four blocks of variable data are sent to the printer.

Data input: 115<CR> 33.7<CR> 62.8<CR> 228.7<CR>

**Actual Print-out:**

13.10.03	13:49:52
Metrix Electronics Ltd. Rankine Road, Daneshill West GB-Basingstoke RG24 8PP	
-----	
Test Number:	115
--- TEST RESULTS! ---	
Ambient Temp	33.7 °C
Burn-in Temp	62.8 °C
Nom. Supply	230 Vac
Actual	228.7 Vac

**Pre-stored texts**

1	Metrix Electronics Ltd.
2	Rakine Road, Daneshill West
3	GB-Basingstoke RG24 8PP
4	-----
5	Test Number: *****
6	--- TEST RESULTS ---
7	Ambient Temp *****°C
8	Burn-in-Temp *****°C
9	Nom. Supply 230 Vac
10	Actual *****Vac

The print-out is 10 texts - 4 with variable data inserted and 6 without.

**Example 3:**  
 A simple way  
 to print a  
 group of texts

This mode can be used to print a group of texts, triggered by a single <CR> input, even if no variable data is required to be inserted.

**NOTE:** Text No. 7 is only preprogrammed with a variable data field.

Data input: <CR>

**Actual Printout:**

15.10.03	10:34:53
Manufactured by::	
-----	
Metrix Electronics Ltd. Rankine Road, Daneshill West GB-Basingstoke RG24 8PP	
-----	

**Pre-stored texts**

1	Manufactured by:
2	-----
3	Metrix Electronics Ltd.
4	Rankine Road, Danneshill West
5	GB-Basingstoke RG24 8PP
6	-----
7	*****

All the texts up to Text No. 6 (without variable fields) are printed. Text No. 7 (the first variable field) just prints a blank line. (If there was any variable data sent before the <CR> this would be inserted and printed here.)

## II Paper reroll mechanism IPP - AW

### 1. General information

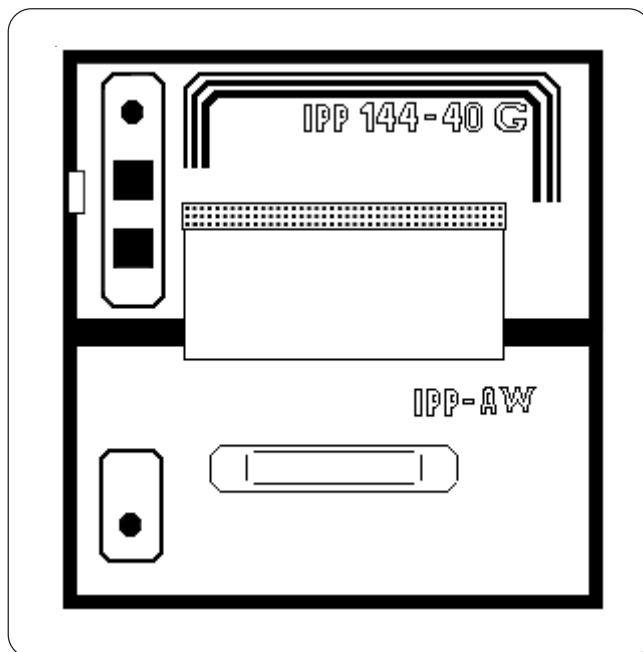

The IPP-AW is a paper reroll mechanism designed for use with the Thermal Graphics Printer IPP 144-40 G. It has been designed to match the printer in colour and style. It is preferably installed directly underneath the printer. The printed paper is automatically wound on a drum by a motor. A swivel front panel allows easy paper handling.

The paper reroll mechanism is a DIN size panel mounting unit. It is supplied with power and controlled via connector cable which comes with the unit and which is connected to connector 12 of the IPP 144-40 G (see chapter I.3.). An LED indicates the ready status. Depending on the distance between the two devices at least the last 9 lines printed remain visible.

## Design

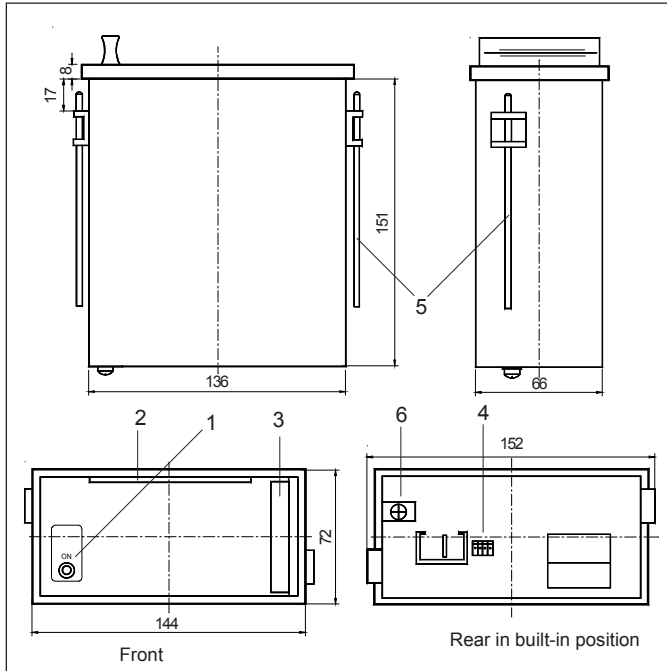

- |   |  |   |  |
|---|--|---|--|
| 1 | Status indicator   | 2 | Opening for paper feed                           |
| 3 | Handle   | 4 | Connector for connection cable IPP 144-40;       |
| 5 | Mounting screws  |   | (pin connections: Motor control, +5V, open, GND) |
| 6 | Protective conductor connection<br>(must be connected to ground) |   |  |

## Installation

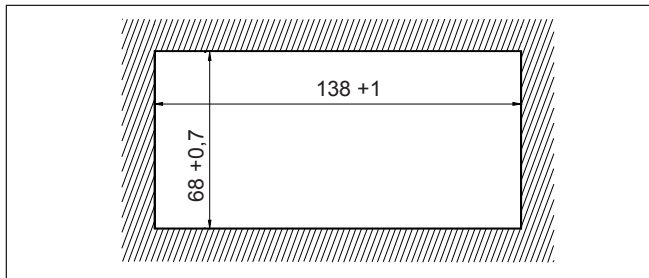

The paper reroll mechanism is inserted into the DIN size panel cutout from the front side and is clamped against the rearside of the switchboard using the mounting screws. The switchboard thickness must not exceed 12 mm.



Make sure that the unit is properly mounted before connection and power on.

## 2. Technical data

### Winding

Motor with friction clutch, electronic lag 3 sec

Paper width: max. 80 mm  
Paper length: max. 15 m

### Ambient conditions

Store temperature range: -20 °C bis +80 °C  
Operating temperature range: 0 °C bis +70 °C  
Climate: relative humidity < 80 % up to 31 °C

### Standards

Protection type housing: IP 50 acc. to EN 60528/VDE 0470  
Mech.strength: acc. to IEC 1010  
Safety: EN 61010-1:2001  
CATIII >150V° ≤ 300V  
Pollution degree 2  
EMV  
Susceptibility: DIN EN 610004-1 to EN 610004-4  
Emission: DIN EN 50081-2 Class B

### Miscellaneous

Dimensions (WxHxD): 144 x 72 x 159 mm

### Connection

Connector: MASCON female multi point connector, 4 pin keyed  
Connector cable: AWG 26, approx. 100mm  
Power supply: by IPP (5 V DC)

CE

### Maintenance friction clutch

The torque of the friction clutch has been factory adjusted and should not require adjustment.

The winding force of the motor can be adjusted by slightly rotating the screw accessible through the left hand side hole in the body:

- ➡ **less** = turn left
- ➡ **more** = turn right

### 3. Operation

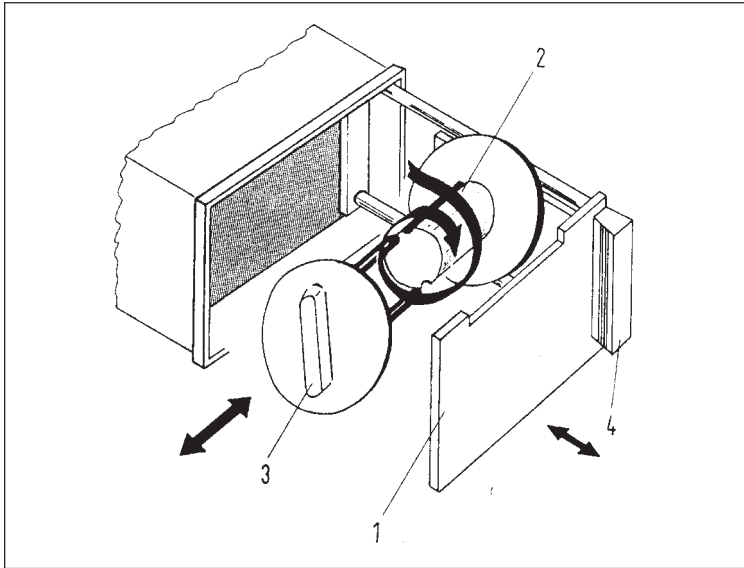

#### Removing the paper

- ➔ Use the handle (4) to pull out the front panel (1).
- ➔ Remove the holder (3) with the paper from roll body, rotate the notch of the holder as show in the diagram.
- ➔ Remove the paper drum from the holder.

#### Inserting the paper

- ➔ Wind the paper once around the drum body (2) in the direction indicated by the arrow.
- ➔ Plug in the holder (3) in such a way that the pins fit into the notches of the body.
- ➔ Close the front panel.
- ➔ Briefly press the „LINE FEED“ key at the IPP 144 - 40 G until the paper has been straightened out.

### III Accessories

- ◆ Paper reroll mechanism IPP - AW  
(incl. connection cable).
  
- ◆ Protection cover for use of IPP 144-40 G with IPP-AW,  
Protection class: IP 64.  
Dimensions: 155 x 155 [mm].  
Material: Plexiglas and  
Santoprene 101-80 caoutchouc
  
- ◆ Connection cable for serial data transmission  
to the following devices:  
  
IBM-PC XT and AT or compatibles  
Siemens PG 685 (V 24)  
Siemens PG 675 / 685 (printer interface)  
Siemens GP270 / TP270 / MP370 TOUCH (RS232C)  
(printer interface)  
Message displays:  
DAA 144-120B / 288-120B / 288-240B, C  
others on request.  
  
Connection cable for USB-interface:  
USB-A connector - USB-B connector





**GOSSEN Müller & Weigert**

Kleinreuther Weg 88 · D-90408 Nürnberg

Telefon ++49(0)911 3502-0 · Telefax++49(0)911 3502-307/305

Internet: <http://www.g-mw.de> · e-mail: [info@g-mw.de](mailto:info@g-mw.de)

**Local distributor**



Trosvik Næringspark  
Strømtangveien 11  
NO-3950 Brevik

Tlf.: +47 35 56 91 00  
Fax: +47 35 56 91 01  
e-post: [post@kongsgaarden.no](mailto:post@kongsgaarden.no)  
web: [www.kongsgaarden.no](http://www.kongsgaarden.no)