

Bar Graph Meters

- For process control, automation and laboratory applications
- Current, voltage, resistance, frequency and temperature
- Resolution up to 0,5 %



Bar Graph Indicators



Model

LK 75

LS 40

LS 100

Special features

- Electronic measuring instrument with band of light emitting diodes (individual LEDs)
- Operation independent of orientation and insensitive to vibration
- 21 LED display
- LED colours on request
- Single-line

- Electronic measuring instrument with band of light emitting diodes (individual LEDs)
- Operation independent of orientation and insensitive to vibration
- 41 LED display
- Measuring range adjustable by DIP switch
- Adjustable span
- LED colours on request
- Single-line

- Electronic measuring instrument with band of light emitting diodes (individual LEDs)
- Operation independent of orientation and insensitive to vibration
- 26 bi-coloured LED display
- Two limit values are adjustable and can be shown on the display
- Adjustable span
- An out of limit value will be signalled
- Four keys for configuration and operation
- Additional three-digit digital display
- Single-line

Dimensions

Bezel size	LK 75	LS 40	LS 100
Depth	75 x 38 mm	96 x 24 mm	96 x 24 mm
Panel cut out	43 mm	68 mm	194 mm
	73.2 x 36 mm	91 x 22.5 mm	91 x 22.5 mm

Versions

Version	LK 75	LS 40	LS 100
1 measuring input, no limit value	none	none	two
1 measuring input, 2 limit values			LS 100-00
2 measuring inputs, no limit value			LS 100-11
2 measuring inputs, 4 limit values			

Number of measuring inputs

Number of measuring inputs	LK 75	LS 40	LS 100
One measuring input	One measuring input	Two measuring inputs	One measuring input (Measuring range card)

Bar graph (analogue display)

Bar graph (analogue display)	LK 75	LS 40	LS 100
LEDs	21 round LEDs (2.5 mm in Diameter)	41 bar type LEDs (2x5 mm)	26 bi-colour LEDs (2x5 mm)
Format	vertical or horizontal format	vertical or horizontal format	vertical or horizontal format
Point or bar type display	point or bar type display	point or bar type display	point or bar type display
Overflow	flashing	flashing	flashing
Centre zero	yes	yes	yes
Scale length	51 mm approx.	80 mm	52 mm
Resolution	5 %	2,5 %	4 %
Colour	red, other colours on request	red, other colours on request	red or green

Digital display

Digital display	LK 75	LS 40	LS 100
Format	none	none	yes Three 7-segment digits

Auxiliary supply

Auxiliary supply	LK 75	LS 40	LS 100
	5 V DC, not galvanically isolated	5 V DC, not galvanically isolated 24 V DC	24 V DC

Measuring range

Measuring range	LK 75	LS 40	LS 100
Voltage	0...60 mV to 0...200 V DC	0...150mV/1 V/10 V/100 V/200 V DC	yes
Current	0...1 mA to 0...200 mA, 4...20 mA DC	0...20 mA, 4...20 mA DC	yes
Resistance			yes
Thermocouple			yes
Frequency			yes

Measuring range card

Measuring range card	LK 75	LS 40	LS 100
Measuring range	no	no	yes see Measuring Range Cards
Zero adjustment	no	no (yes, 4...20 mA)	yes
Full-scale adjustment	yes	yes	yes

Limit values

Limit values	LK 75	LS 40	LS 100
Number Adjustable	none	none	two Keys
Presentation on scale			Different coloured LED
Signalling			Keys-LED
Outputs			Two Relays
Hysteresis			1% approx. (others on request)

Analogue Output

Analogue Output	LK 75	LS 40	LS 100
Value	none	none	yes (optional) 0...1 VC DC not galvanically isolated from the measuring circuit.



LS 200



LS 300



LS 500

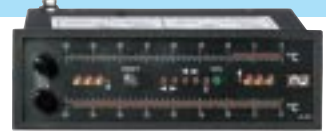
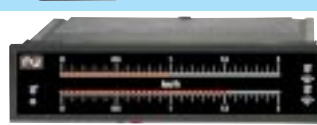

Model

Special features

- | | | |
|---|---|---|
| <ul style="list-style-type: none"> ● Electronic measuring instrument with gas discharge display ● Operation independent of orientation and insensitive to vibration ● 201 distinguishable segments ● Four limit values are adjustable and can be displayed ● Adjustable span ● Out of limit values will be signalled ● Controls to adjust limit values | <ul style="list-style-type: none"> ● Electronic measuring instrument with light emitting diode display ● Operation independent of orientation and insensitive to vibration ● 101 distinguishable segments ● Two limit values are adjustable and can be displayed ● Adjustable span ● Out of limit values will be signalled ● Controls to adjust limit values ● Controls to adjust the start and final value of the analogue display and to set brightness ● Serial interface | <ul style="list-style-type: none"> ● Electronic measuring instrument with light emitting diode display ● Operation independent of orientation and insensitive to vibration ● 101 distinguishable segments ● Four limit values are adjustable and can be displayed ● Adjustable span ● Out of limit values will be signalled ● Controls to adjust limit values ● Serial interface ● Additional three-digit digital display per analogue bar |
|---|---|---|

Dimensions	Bezel size	144 x 48 mm	144 x 36 mm	144 x 48 mm
	Depth	163 mm	171 mm	200 mm approx.
	Panel cut-out	138 x 45 mm	138 x 32,7 mm	138 x 45 mm

Versions

1 measuring input, no limit value	LS 210	LS 310	LS 510
1 measuring input, 2 limit values	LS 212	LS 312	LS 512
2 measuring input, no limit value	LS 220	LS 320	LS 520
2 measuring input, 4 limit values	LS 224		LS 524

Number of measuring inputs	Two measuring inputs (Measuring range card)	Two measuring inputs (Measuring range card)	Two measuring inputs (Measuring range card)
-----------------------------------	--	--	--

Bar graph (analogue display)	Gas discharge display 201 Segments vertical or horizontal format	LED bars 101 LEDs vertical or horizontal format point or ribbon type display	LED bars 101 LEDs vertical or horizontal format point or ribbon type display
Overflow	flashing	flashing	flashing
Centre zero	no	yes	yes
Scale length	100 mm	100 mm	100 mm
Resolution	0,5%	1%	1%
Colour	neon-red	red	red

Digital display	none	none	one or two Three 7-segment digits
Format			

Auxiliary supply	24 V AC 110/220 V AC 115/230 V AC 24 V DC	24 V AC 115/230 V AC 24 V DC 48 V DC	24 V AC 115/230 V AC 24 V DC 48 V DC
-------------------------	--	---	---

Measuring ranges	Voltage	yes	yes	yes
	Current	yes	yes	yes
	Resistance	yes	yes	yes
	Thermocouple	yes	yes	yes
	Frequency	yes	yes	yes

Measuring range card	yes	yes	yes
Measuring range	see Measuring Range Cards	see Measuring Range Cards	see Measuring Range Cards
Zero adjustment	yes	yes	yes
Full-scale adjustment	yes	yes	yes

Limit values	Number	Four	Two	Four
	Adjustable	Potentiometer	Potentiometer	Potentiometer
	Presentation on scale	Pointer	LED-Bar or LED-Point	Pointer
	Signalling	LED	LED	LED
	Outputs	Four Relays	Two Relays	Four Relays
	Hysteresis	0,5% approx.	1% approx.	1% approx.

Analogue Output	Value	none	yes (one optional) 0...10 V or 0/4...20 mA	yes (two optional) 0...10 V or 0/4...20 mA
------------------------	-------	------	--	--

Bar Graph Meters



OPr 144



KoOPr 144

Bar graph meters can indicate the value of a measured signal from a sensor, for example, connected directly to the meter, or via a transducer. Depending on the display resolution, bar graph meters can be classed as simple trend indicators, general-purpose meters or measuring instruments. In most models the scale markings overlay the indicating bar graph, but in some models the scale is integrated into the illuminated display itself.

Bar graph meters offer a genuine alternative to normal analogue pointer instruments, but with the added advantages of greater robustness – making them less sensitive to shock and vibration – and the ability to operate in any orientation. The displays can also be multicoloured and the indication can be as a moving point, or as a ribbon type display. In some models the bar graph display is complemented by a digital readout.

Unlike simple analogue pointer meters, bar graph meters are electronic and require an auxiliary power supply. They therefore have a high cost price, but can easily include additional features such as limit alarms, transducer power source, analogue outputs and digital interfaces.

The Müller & Weigert bar graph meter series covers the range from simpler trend indicators up to accurate analogue measuring instruments with two independent illuminated bars.

All models are housed in DIN-size enclosures (except for model LK75, which is designed to be a direct replacement for analogue pointer instruments in the same housing) and can easily be built into instrument panels or cabinets.

There is a choice of display technologies. Single Light emitting diodes offering every possible colour combination, light emitting diode bands, fluorescent displays and plasma displays are all available. In addition, the displays can signal input over or under range conditions and the alarm limit status of up to four limit switches (relays or electrical outputs).

Some models offer BCD-Data inputs or outputs, serial interface (RS-232) or an analogue output.

The choice of auxiliary supply voltages varies from 5 V or 24 V DC for the simple models to comprehensive DC an AC options for the more sophisticated models.

Special features

- Electronic measuring instrument with fluorescence display
- Operation independent of orientation and insensitive to vibration
- 100 distinguishable segments
- Controls to adjust the start and final value of the display
- Adjustable span
- BCD output – optional
- BCD input – optional
- Serial interface
- Additional three-digit digital display
- Single-line

Dimensions	Bezel size	144 x 36 mm	144 x 36 mm
	Depth	226 mm	270 mm
	Panel cut-out	138 x 32.7 mm	138 x 32.7 mm

Versions	none	none
1 measuring input, no limit value		
1 measuring input, 2 limit values		
2 measuring input, no limit value		
2 measuring input, 4 limit values		

Number of measuring inputs	One measuring input (measuring range card)	One measuring input (measuring range card)
----------------------------	--	--

Bar graph (analogue display)	Fluorescent display 100 Segments vertical format point or ribbon type display	Fluorescent display 100 Segments vertical format point or ribbon type display
Overflow	flashing	flashing
Centre zero	yes	yes
Scale length	100 mm	100 mm
Resolution	1 %	1 %
Colour	green	green

Digital display	yes	yes
Format	Three 7-segment digits	Three 7-segment digits

Auxiliary supply	240 V AC 115/230 V AC 24 V AC 5–12 V or 15–24 V DC	240 V AC 115/230 V AC 24 V AC 5–12 V or 15–24 V DC
------------------	---	---

Measuring ranges	yes	yes
Voltage	yes	yes
Current	yes	yes
Resistance	yes	yes
Thermocouple	yes	yes
Frequency		

Measuring range card	yes	yes
Measuring range	see Measuring Range Cards	see Measuring Range Cards
Zero adjustment	yes	yes
Full-scale adjustment	yes	yes

Limit values	None	Four Potentiometer Bright Segment/Beam signalling Flashing Four Relays 1% approx.
Number Adjustable		
Presentation on scale		
Signalling		
Outputs		
Hysteresis		

Analogue Output	Optional for Temperature and True RMS 1 mV/digit	Optional for Temperature and True RMS 1 mV/digit
Value		

MEASURING RANGE CARDS

for LS 100, LS 200, LS 300 and LS 500, OPr and KoOPr

Direct voltage Measuring range Range suppression	0...10 mV to 0...250 V/Overload 350 V max. Up to 50% of the full-scale value
Direct current Measuring range Range suppression	0...20 μ A to 0...200 mA/Overload 0.5 W max. Up to 50% of the full-scale value
Alternating voltage (Sine) Measuring range Frequency range	0...60 mV to 0...250 V/Overload 350 V max. 10 Hz...35 Hz...2kHz...4 kHz
Alternating current (Sine) Measuring range Voltage drop Frequency range	0...10 μ A to 0...1 A/Overload 0.5 W max. 60 mV approx. 10 Hz...35 Hz...2 kHz...4 kHz
Alternating voltage True RMS Measuring range Frequency range	0...60 mV to 0...250 V/Overload 350 V max. DC, 15 Hz...10 kHz
Alternating current True RMS Measuring range Voltage dropl Frequency range	0...2 mA to 0...2A/Overload 0.5 W max. 60 mV approx. DC, 15 Hz...10 kHz
Frequency (not KoOPr.) Measuring range Maximum input	20 Hz...2 kHz Input voltage range up to 25 V 100 V Input voltage range up to 250 V 350 V
Temperature with thermocouple sensor Measuring range	NiCr-Ni (K) 0...1200 °C Fe-CuNi (J or L) 0... 900 °C Cu-Cu-Ni (T or U) 0... 600 °C PtRh-Pt 10% (S) 400...1700 °C PtRh-Pt 13% (R) 500...1700 °C
Temperature resistance thermometer Pt 100 Measuring range	-200 °C...850 °C
Resistance or potentiometer Measuring range	20 Ω ...20 k Ω
Direct Voltage/Direct current switchable (only LS 100) Measuring range Current Voltage	0...1 mA, 0...20 mA, 4...20 mA 0...10 V

Example Order

Model & format:	LS 524, vertical scale, black
Measuring input 1:	0...100 V, ribbon type display 0...100%
Measuring input 2:	0...20 mA, point display 0...4 bar
Auxiliary supply voltage:	24 V DC
Limit values	- Measuring input 1: - Measuring input 2:
Analogue output 1:	0...20 mA
Analogue output 2:	0...10 V

Dimensional Drawings

LK 75

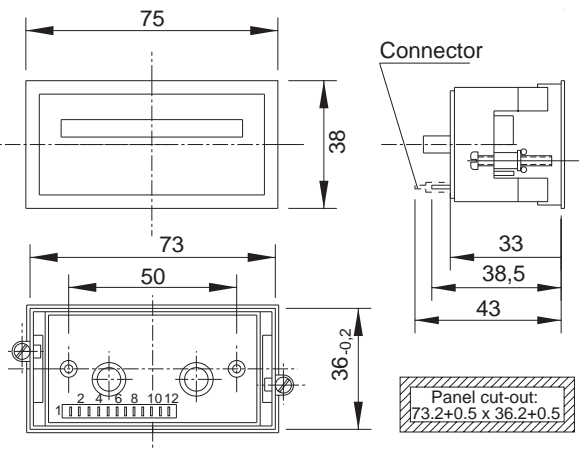

LS 40

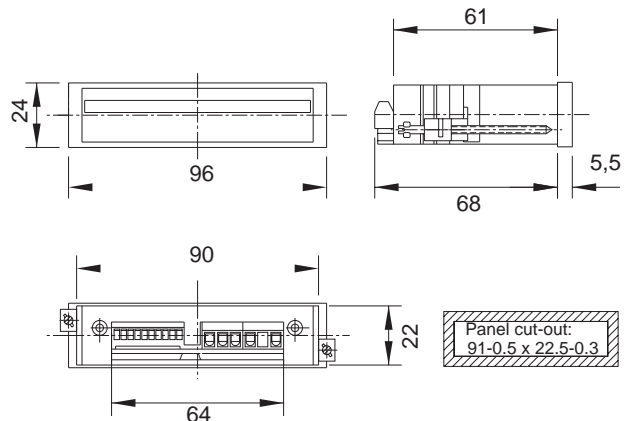

Dimensional Drawings

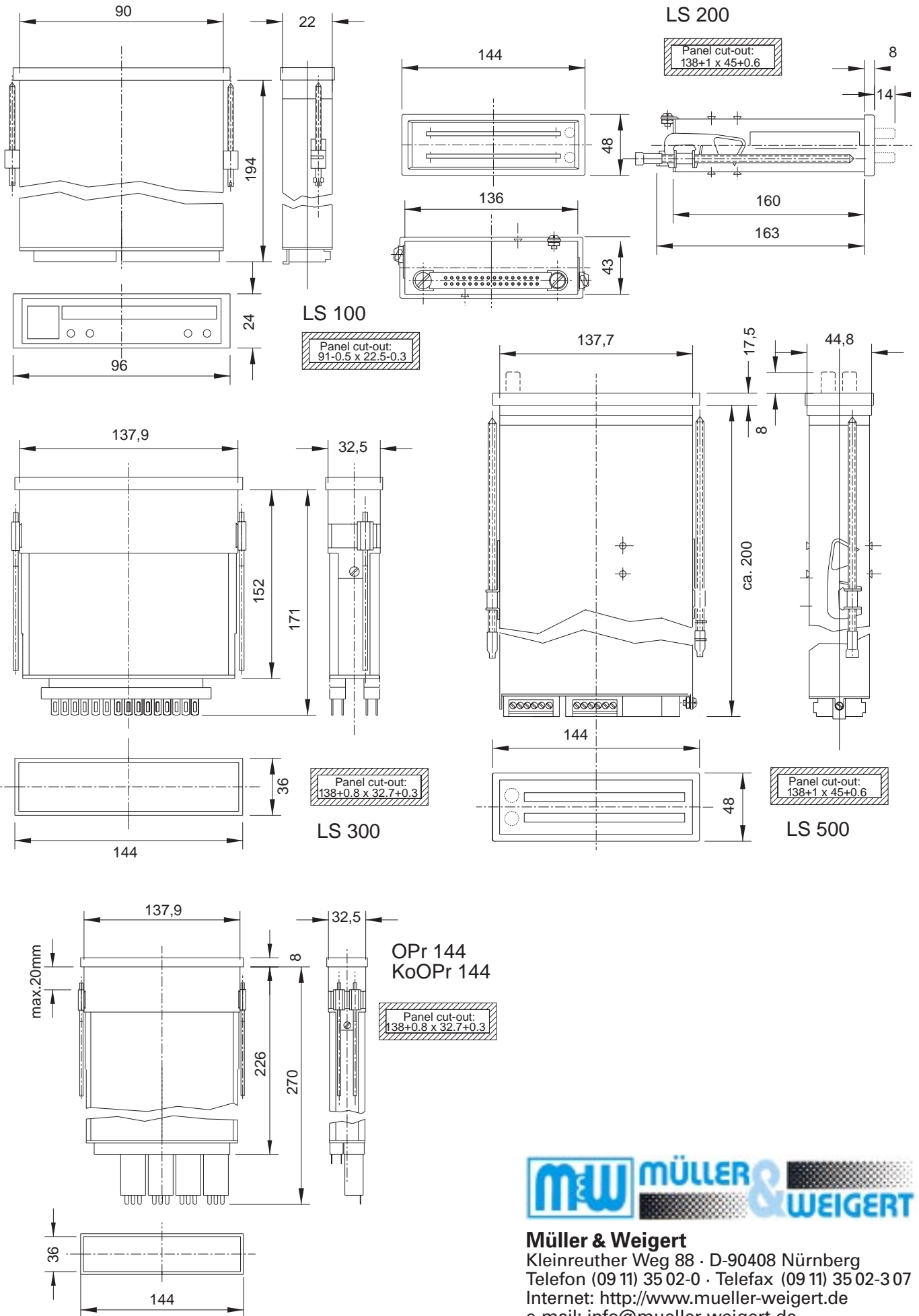

Müller & Weigert
 Kleinreuther Weg 88 · D-90408 Nürnberg
 Telefon (09 11) 35 02-0 · Telefax (09 11) 35 02-3 07
 Internet: <http://www.mueller-weigert.de>
 e-mail: info@mueller-weigert.de