

PBF1144

T=19,5

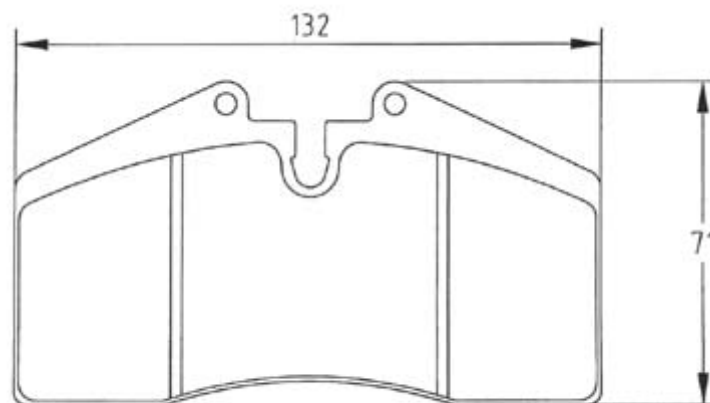

PBF1204

T=18

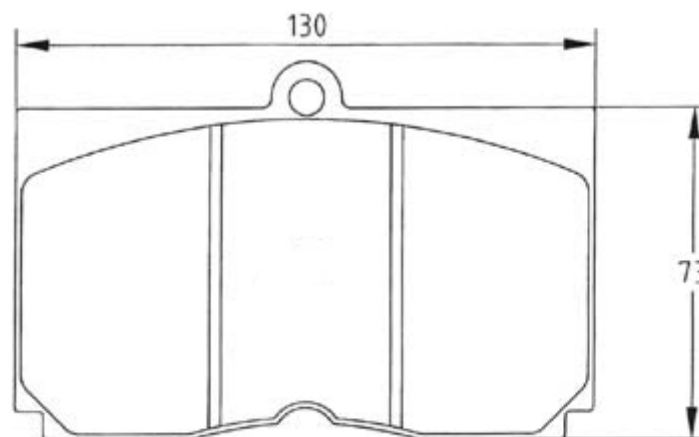

PBF1218

PBF1220

T=20

T=25

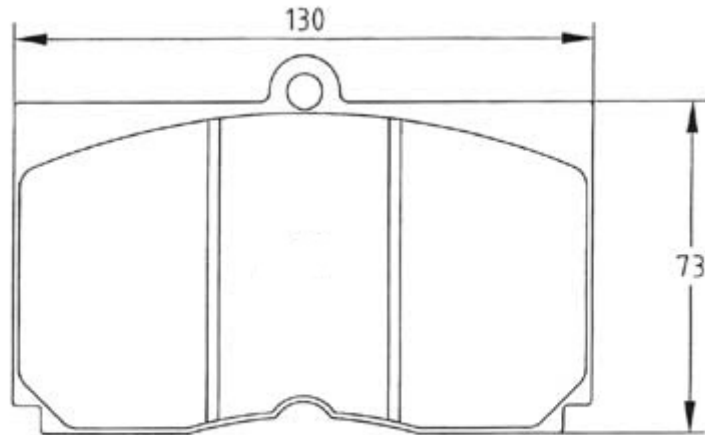

PBF1218
PBF1220

T=20
T=25

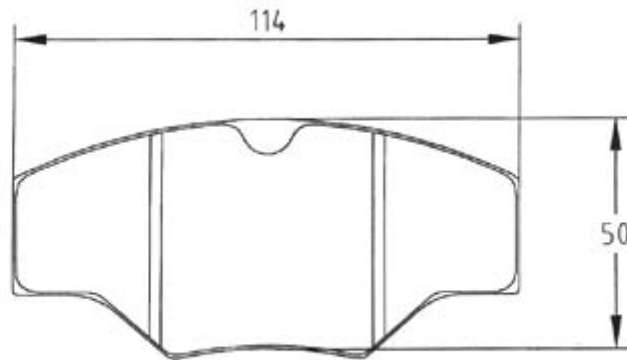

PBF1265
PBF1360

T=16
T=20

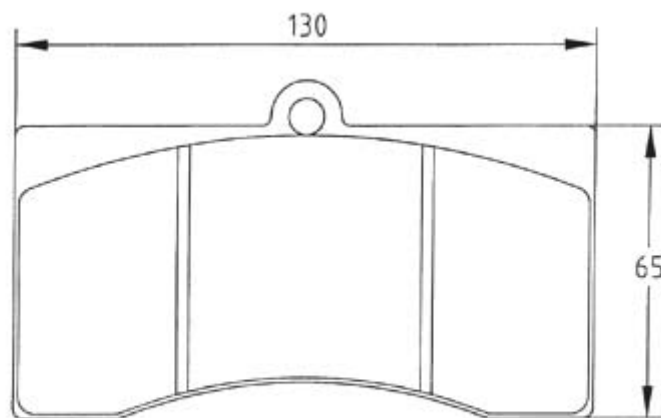

PBF1267
PBF1268

T=20
T=25

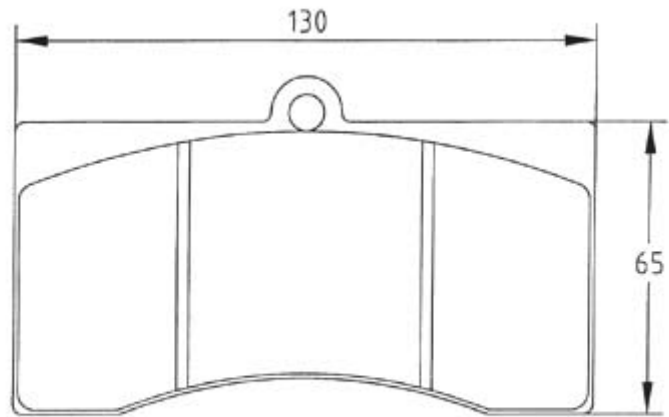

PBF1267
PBF1268

T=20
T=25

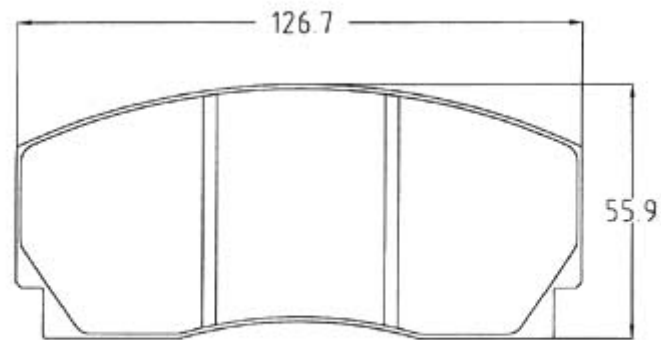

PBF1269

T=17

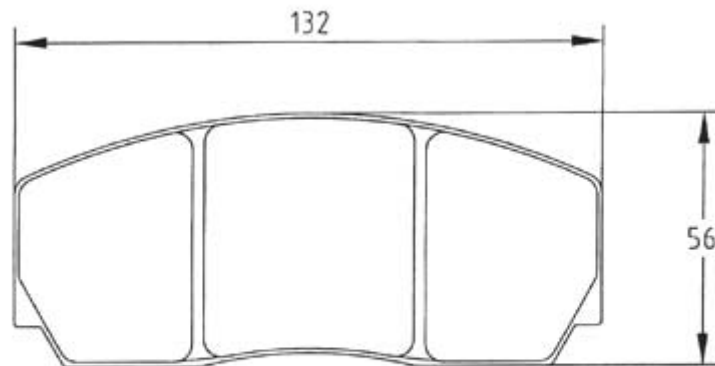

PBF1270
PBF1361

T20
T17

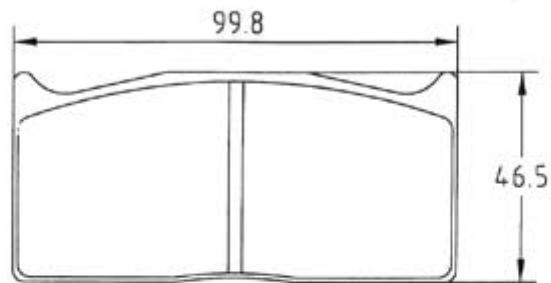
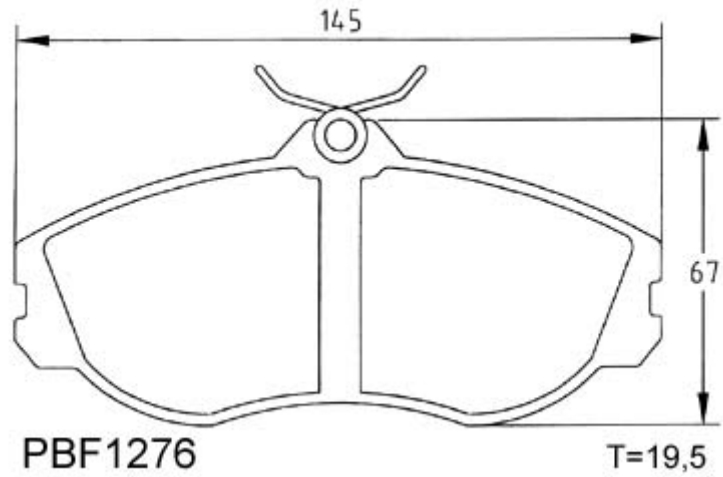

PBF1283 T=20
PBF1705 T=16

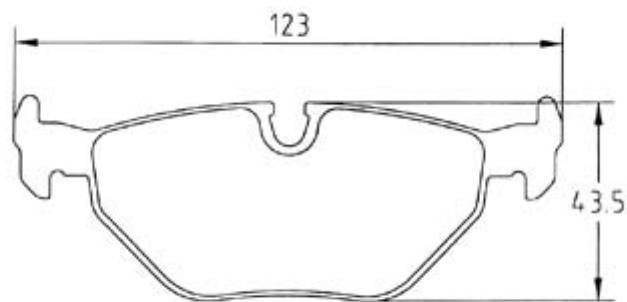

PBF1285 T=16,8

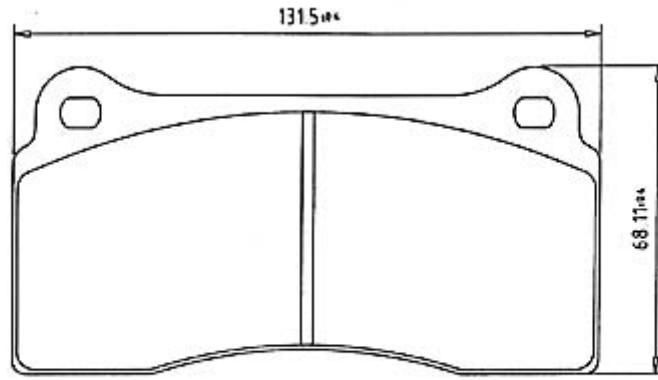

PBF1287

T=18

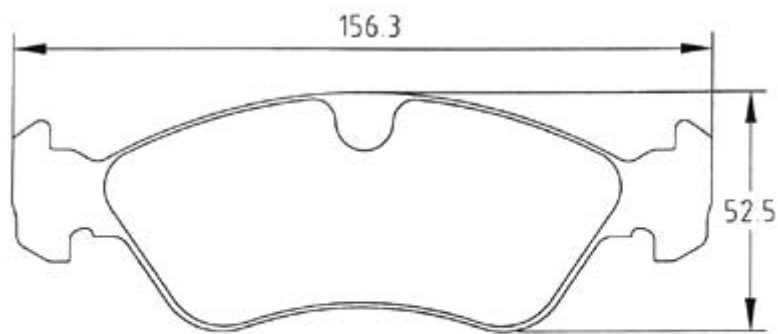

PBF1288

T=17,5

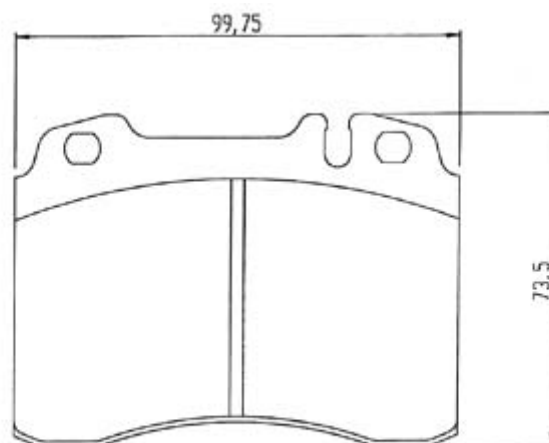

PBF1291

T=17,8

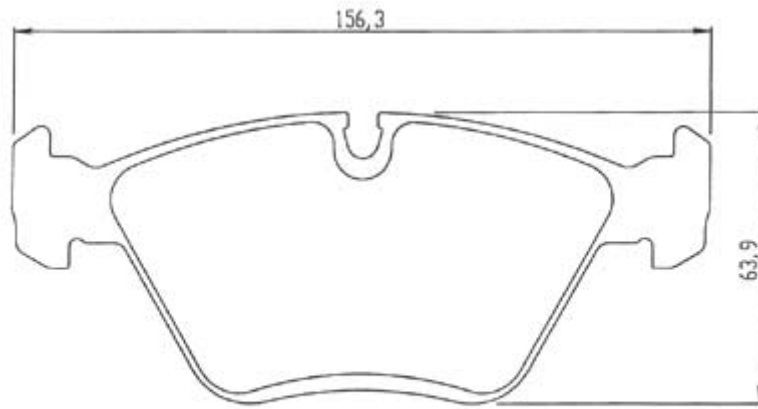

PBF1296

T=19,8

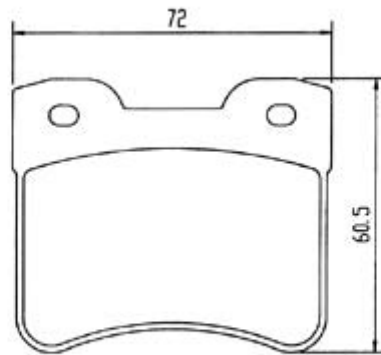

PBF1309

T=16,8

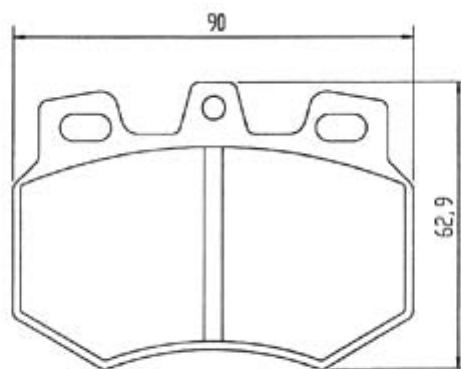

PBF1319

T=17

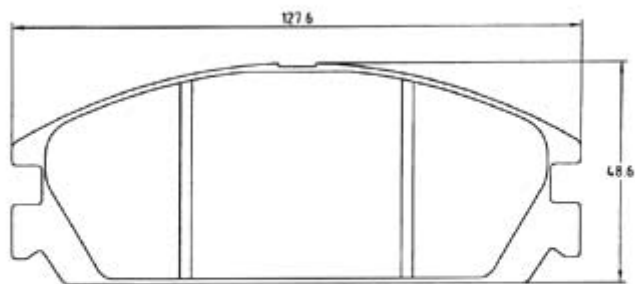

PBF1322

T=14

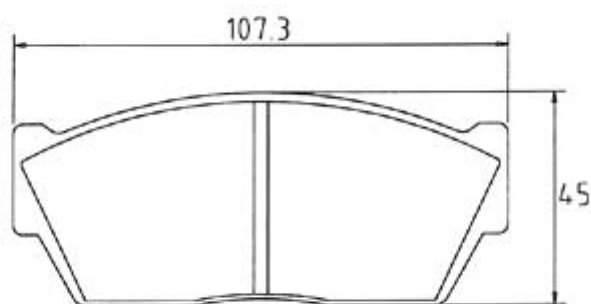

PBF1323

T=14,5

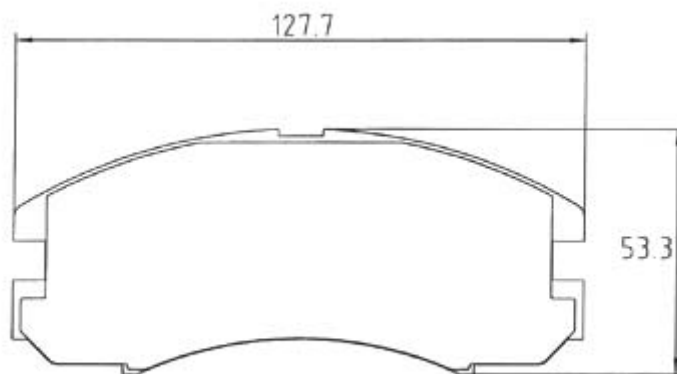

PBF1349

T=15

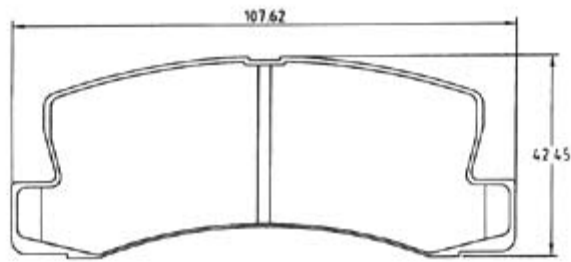

PBF1350

T=15,5

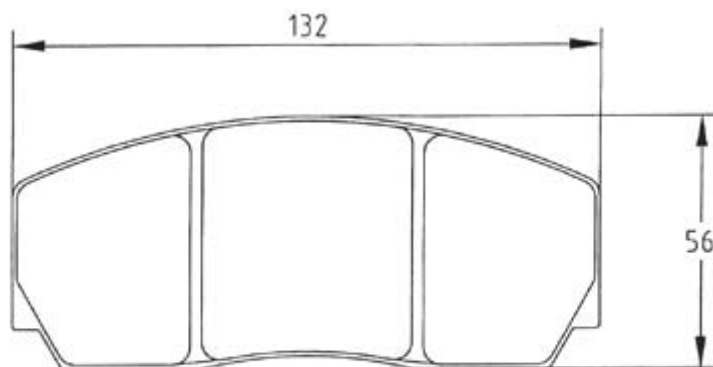

PBF1270
PBF1361

T20

T17

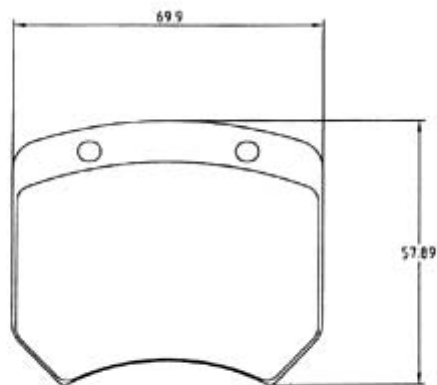

PBF1363

T=15

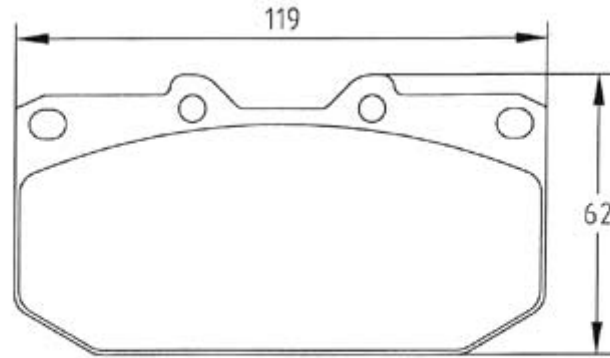

PBF1406

T=14,5

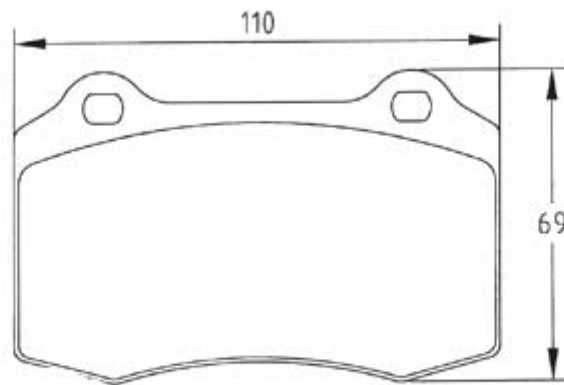

PBF1408

T=18

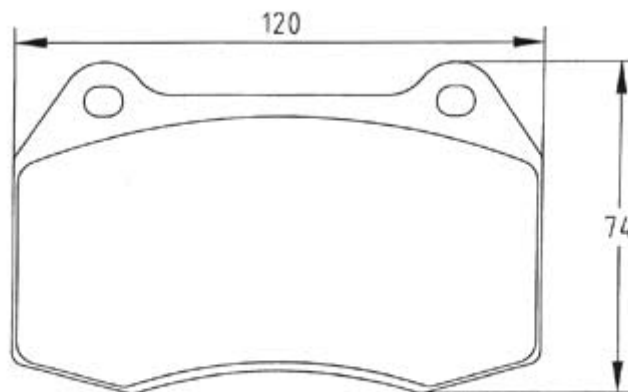

PBF1427

T=18

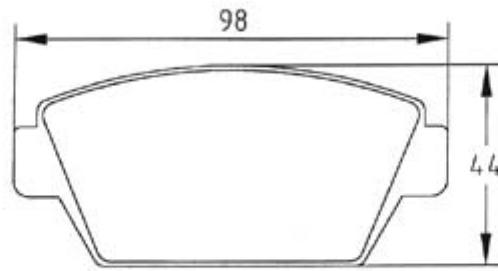

PBF1430

T=14

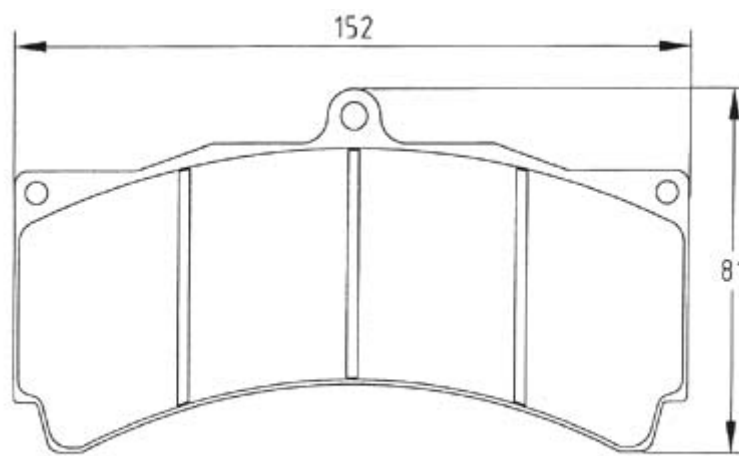

PBF1536
PBF1903

T=25
T=18

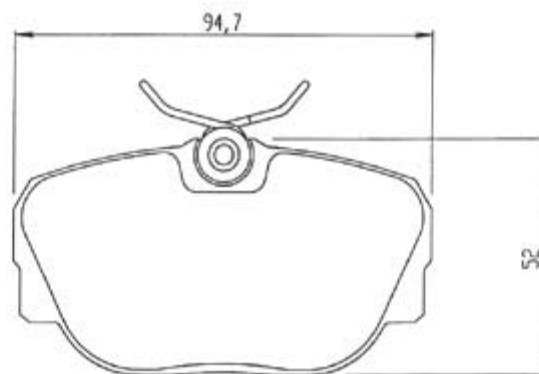

PBF1544

T=17,5

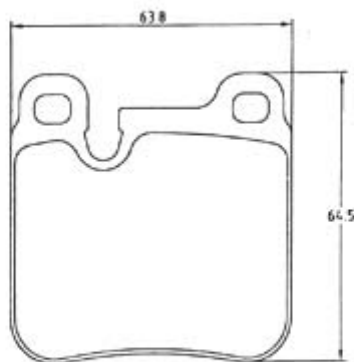

PBF1580

T=14,5

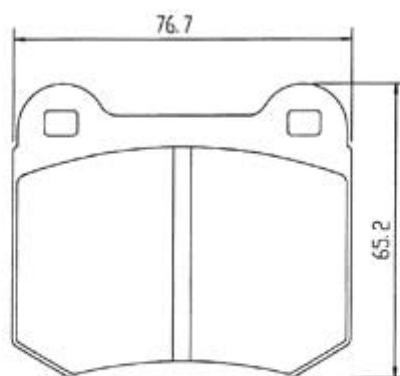

PBF1587

T=15

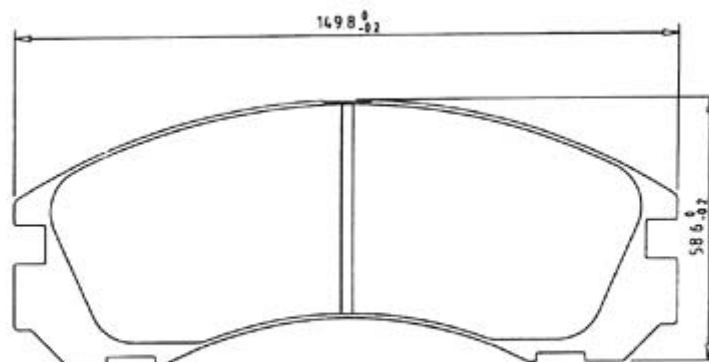

PBF1591

T=15,6

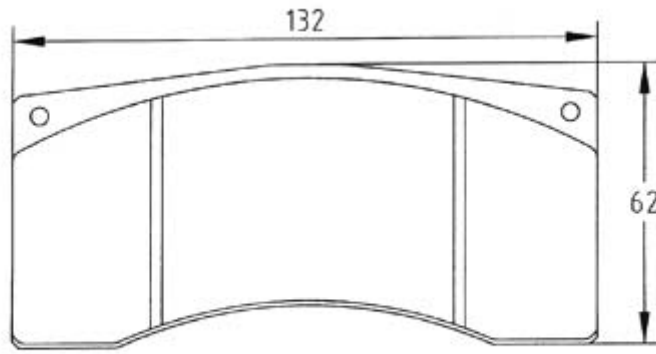

PBF1595
PBF1607

T=16
T=20

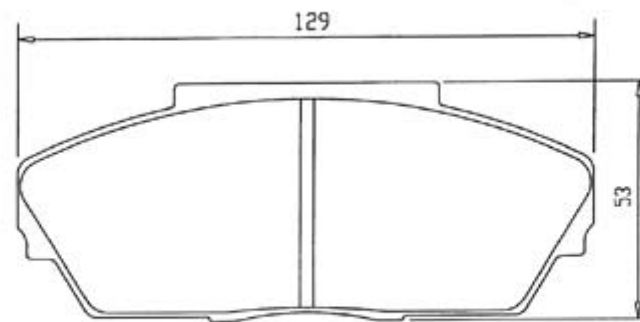

PBF1596

T=17,5

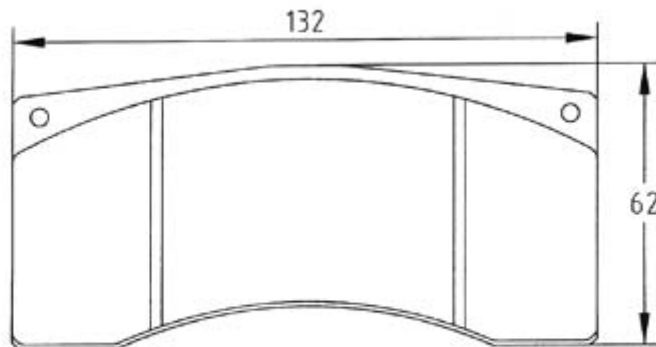

PBF1595
PBF1607

T=16
T=20

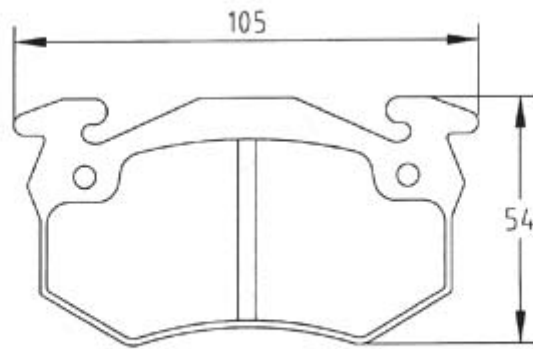

PBF1609
PBF1610

T=17,5
T=12

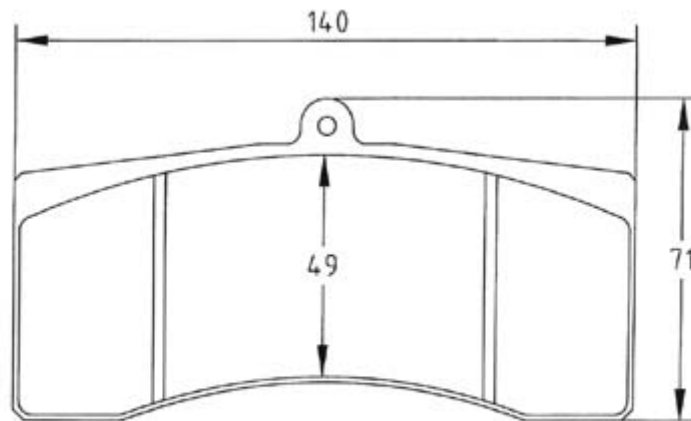

PBF1619
PBF1896

T=25
T=20

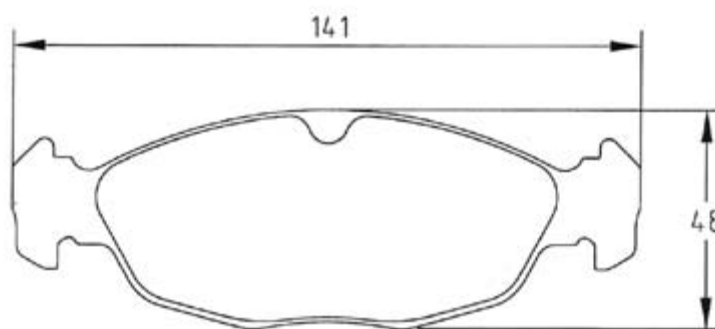

PBF1620

T=16,5

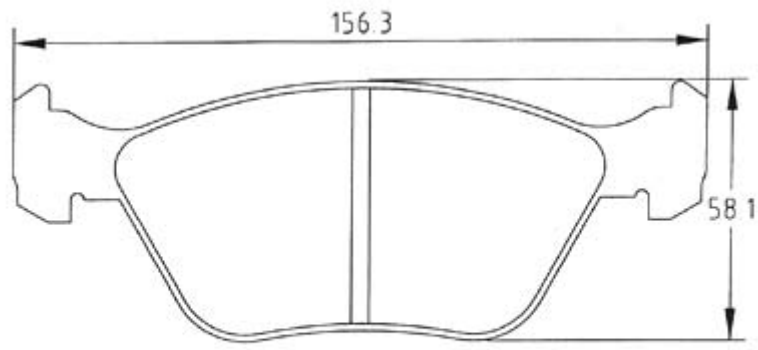

PBF1675

T=19

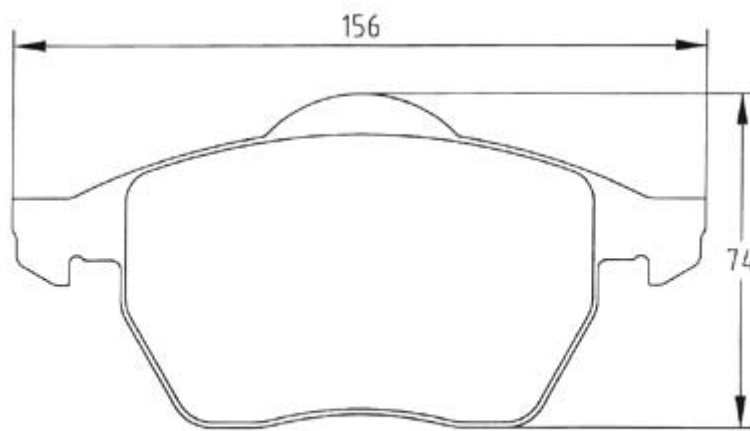

PBF1678

T=19,5

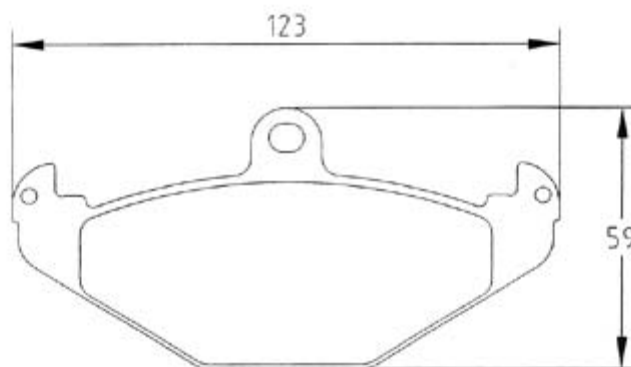

PBF1682

T=15

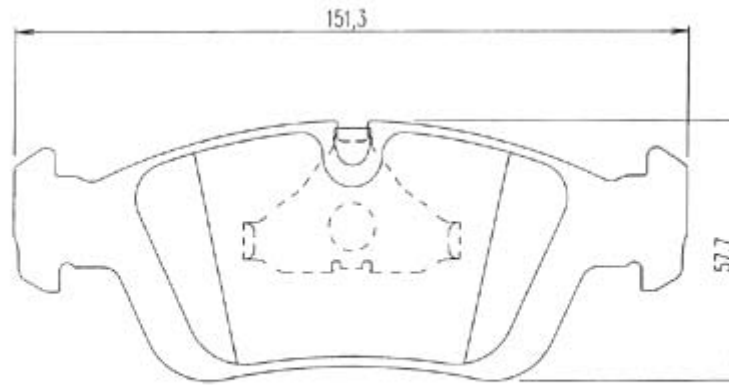

PBF1697

T=17

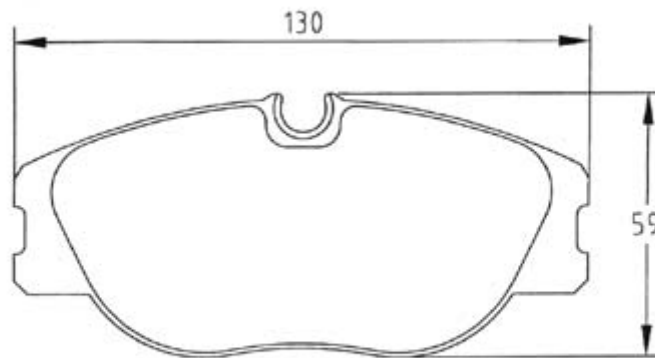

PBF1702

T=19

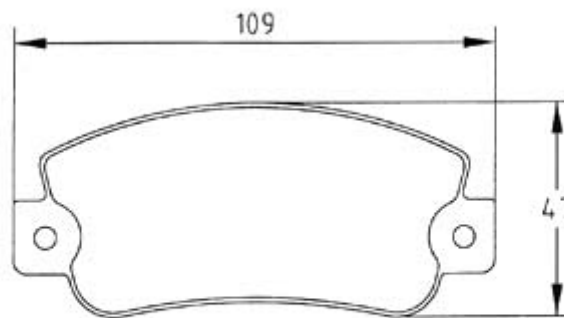

PBF1703

T=12

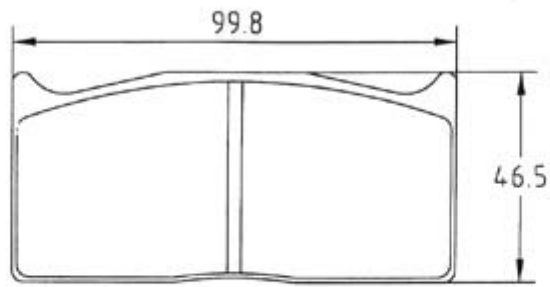

PBF1283
PBF1705

T=20
T=16

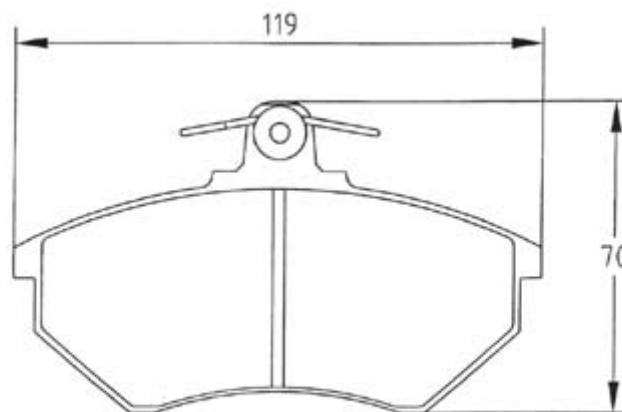

PBF1743
PBF1744

T=16
T=19,5

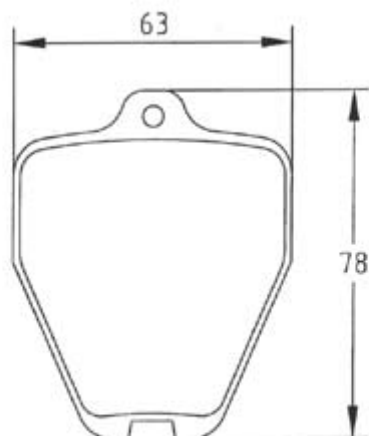

PBF1753

T=18,5

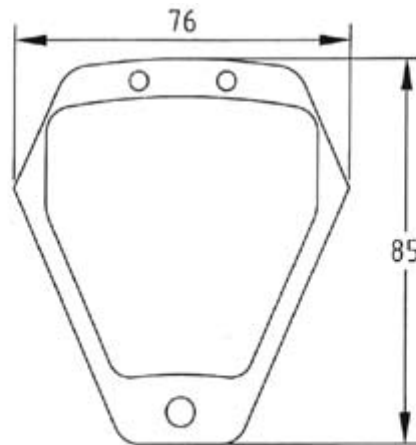

PBF1754

T=17

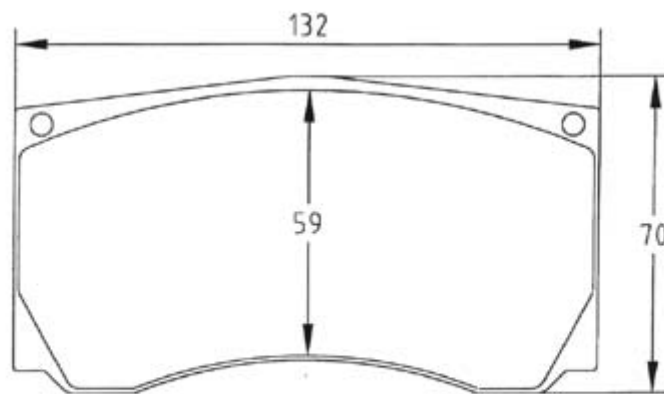

PBF1756
PBF1802

T=20

T=16

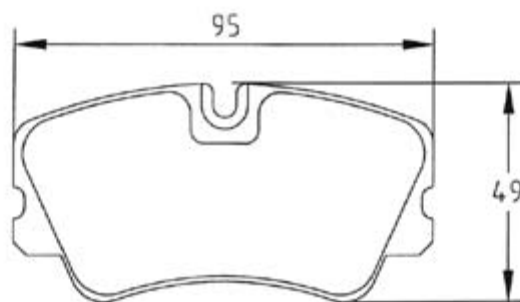

PBF1760

T16,3

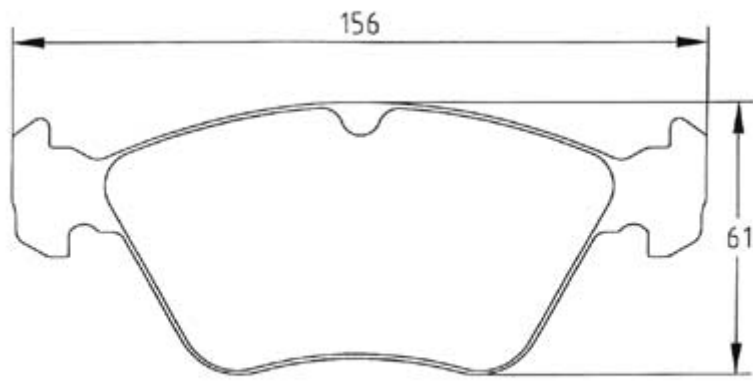

PBF1787

T17,5

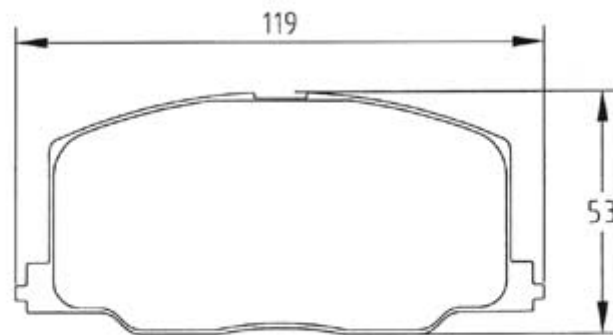

PBF1801

T=15,5

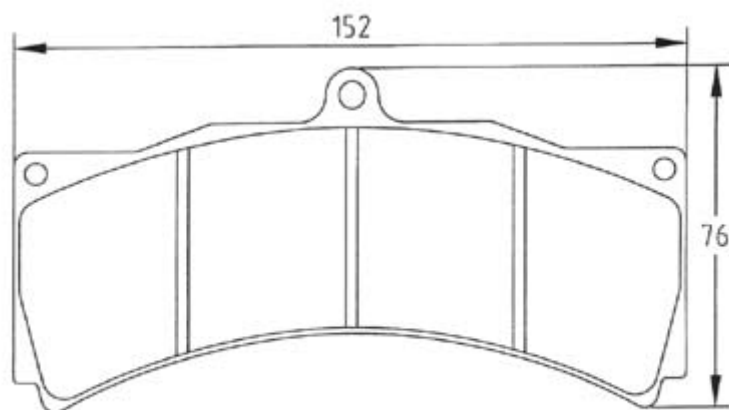

PBF1813

T=25

PBF1852

T=18

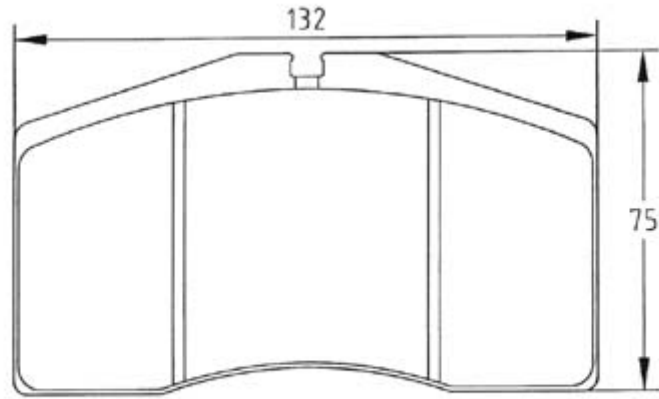

PBF1842
PBF1908

T=17,5
T=24

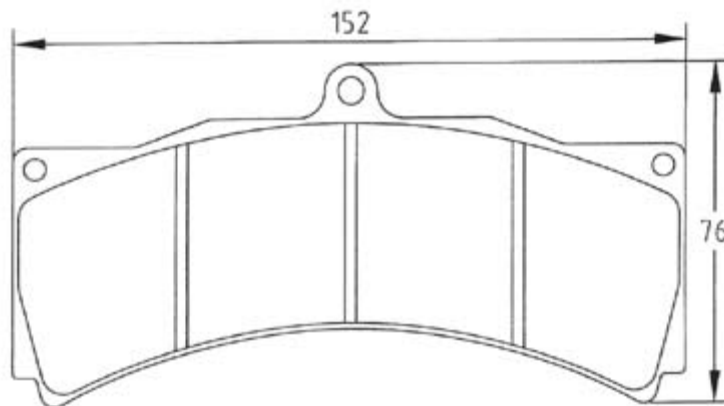

PBF1813
PBF1852

T=25
T=18

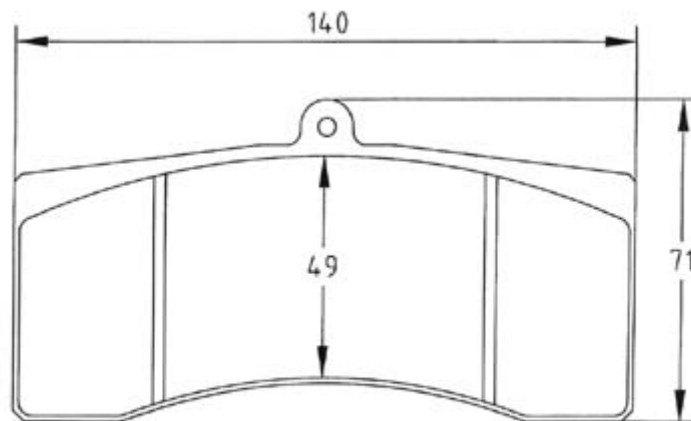

PBF1619
PBF1896

T=25
T=20

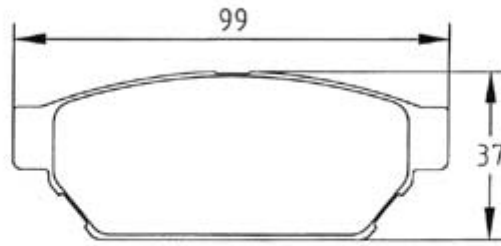

PBF1897

T=14,5

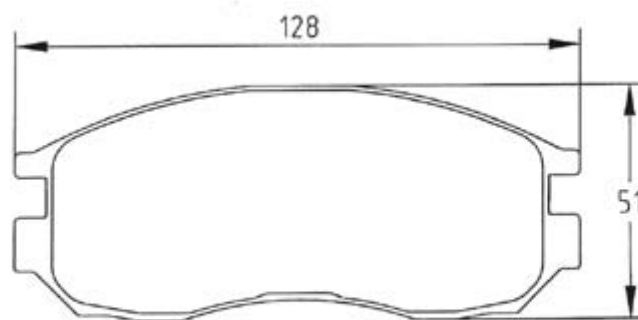

PBF1898

T=16

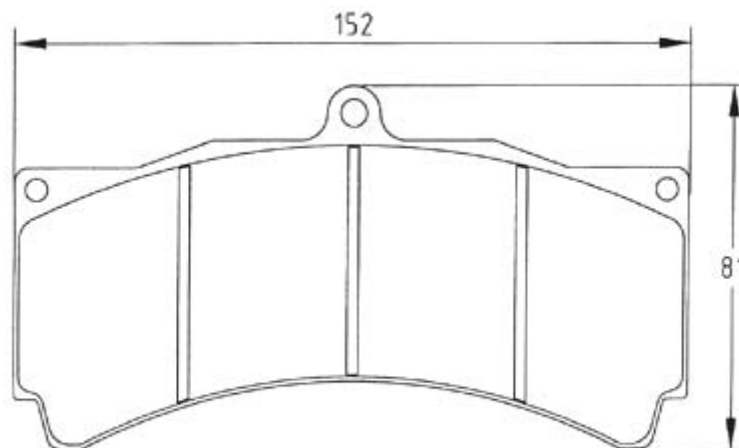

PBF1536

T=25

PBF1903

T=18

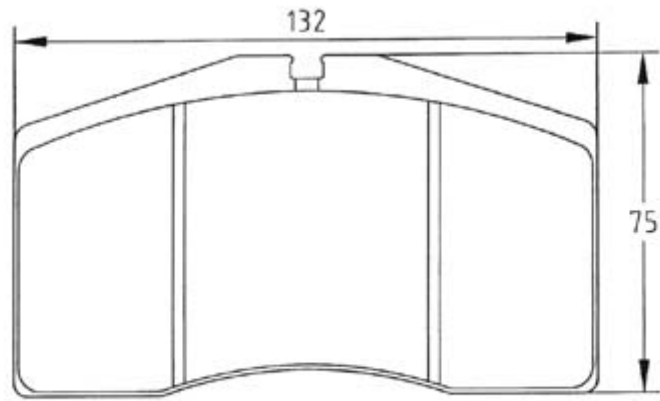

PBF1842
PBF1908

T=17,5
T=24

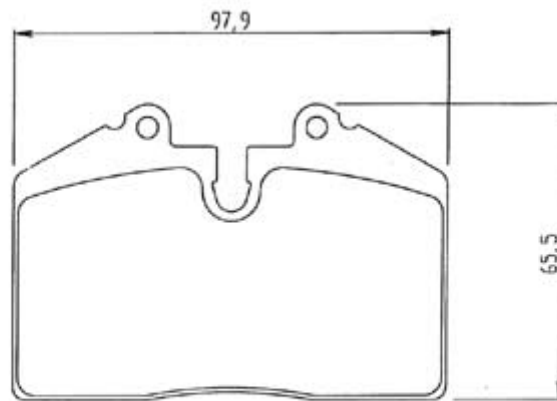

PBF1203
PBF1916

T=17,5
T=24

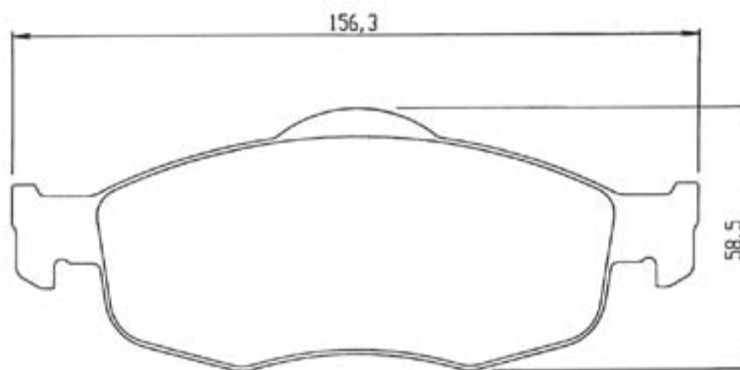

PBF1917

T=18

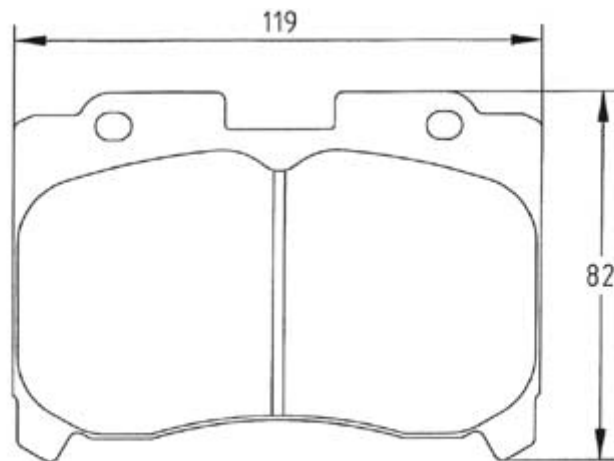

PBF1967

T=17

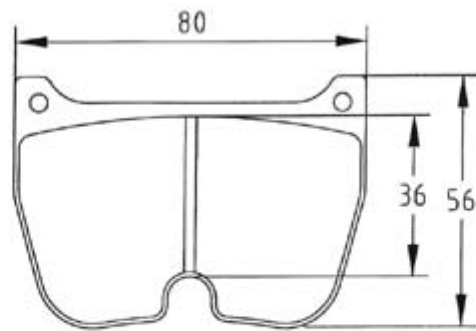

PBF2053

T=20

PBF2129

T=18

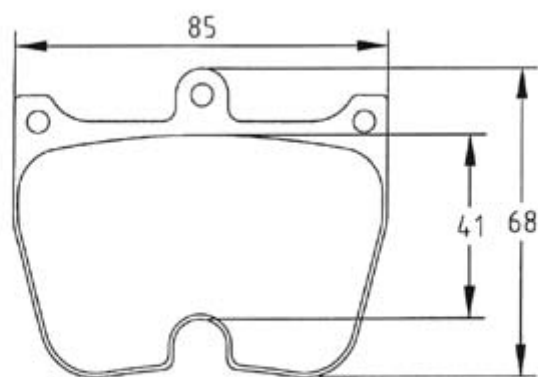

PBF2105

T=22

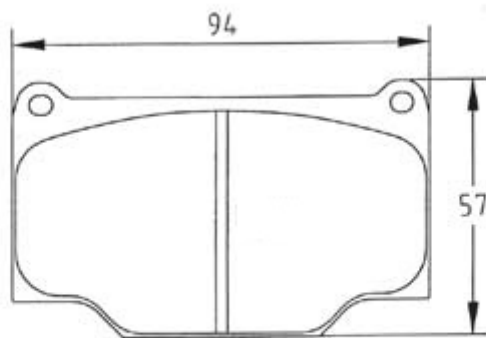

PBF2125

T=17

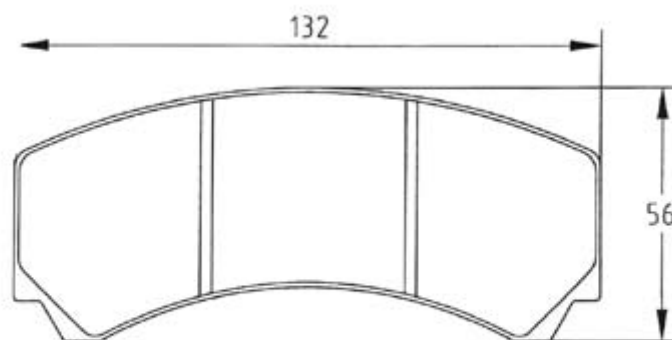

PBF2126

T=17

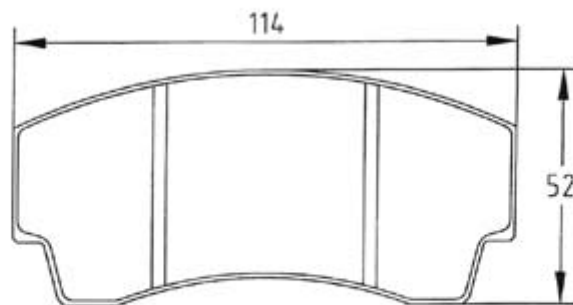

PBF2127

T=16

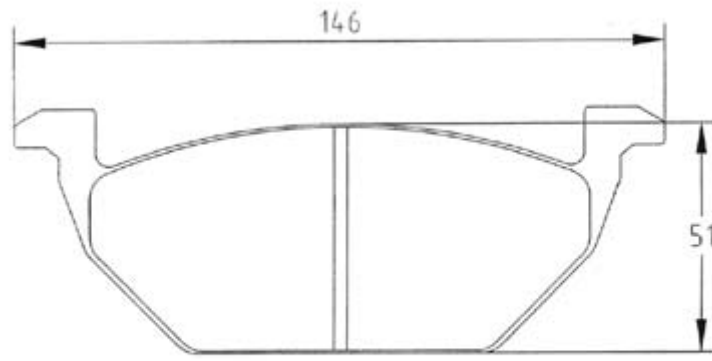

PBF2130

T=19,4

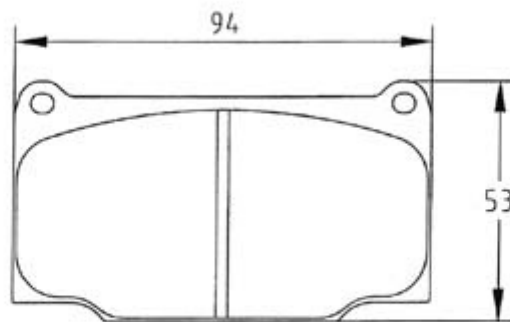

PBF2141

T=16,5

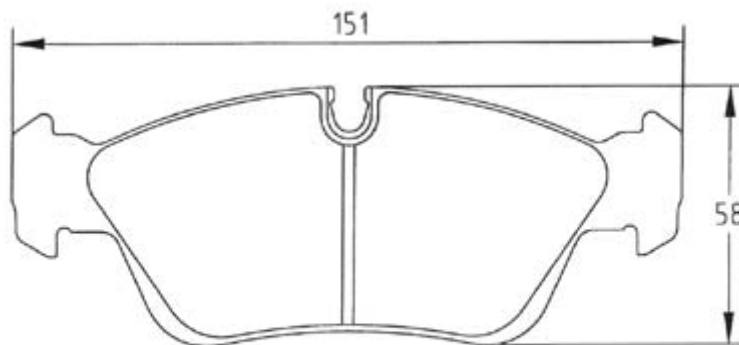

PBF2180

T=17,2

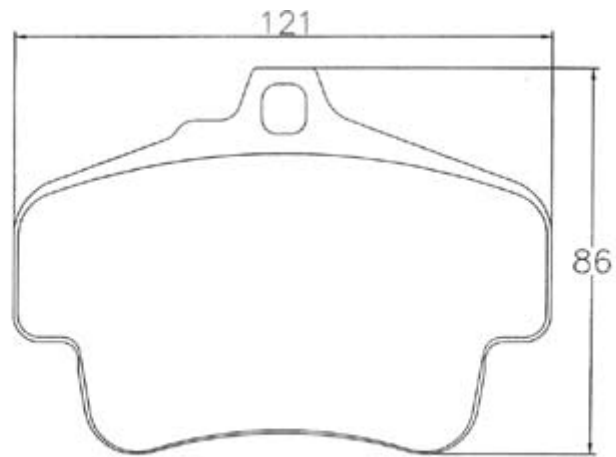

PBF2405

T=18,5

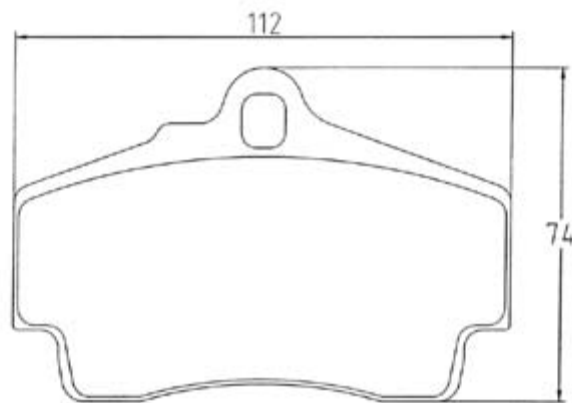

PBF2406

T=15,5

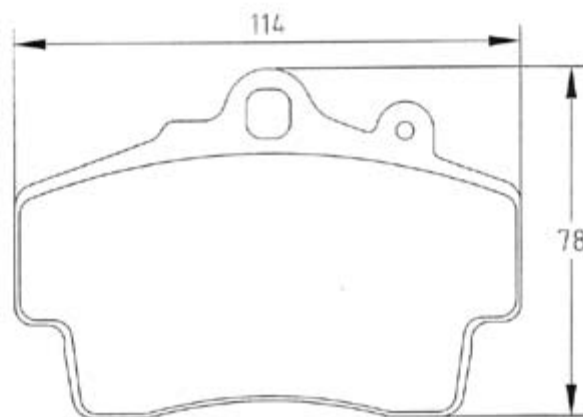

PBF2407

T=15,5

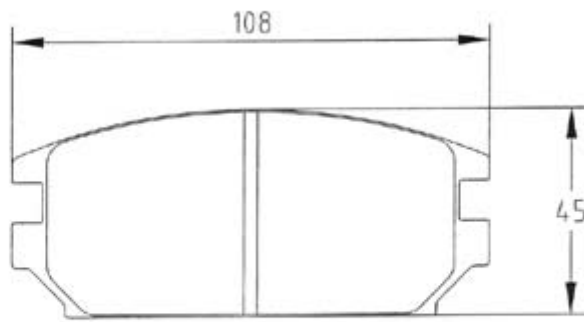

PBF2445

T=15,5

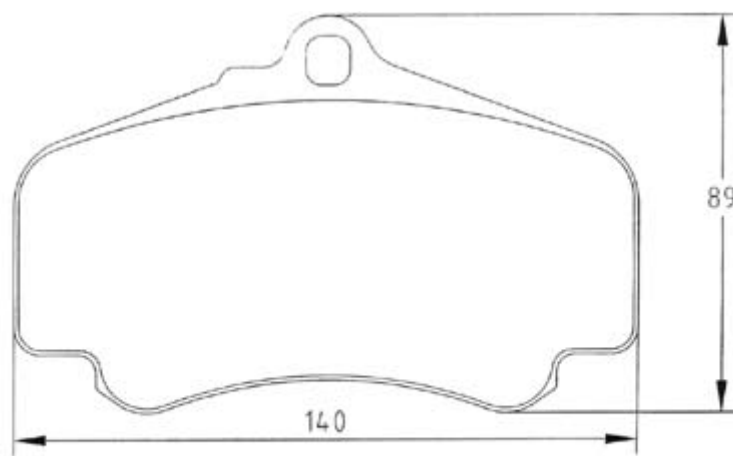

PBF2474

T=18,5

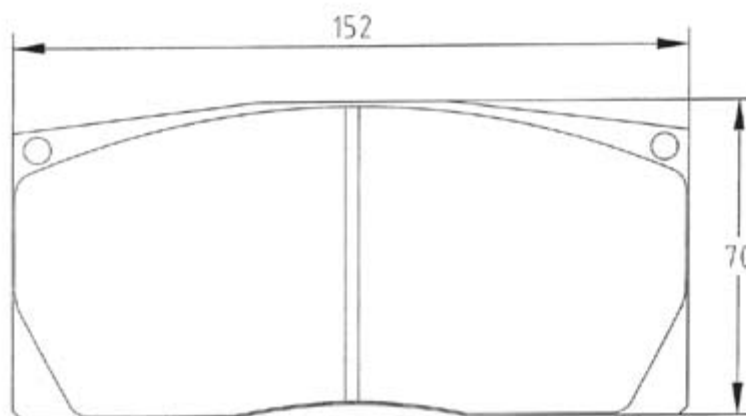

PBF2475

PBF2485

T=20

T=30

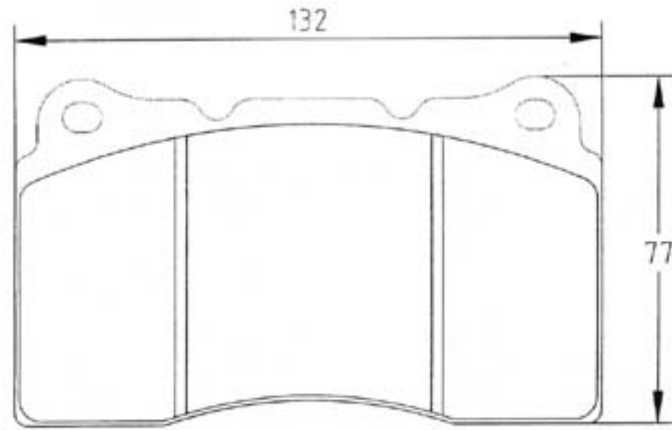

PBF2487

T=16

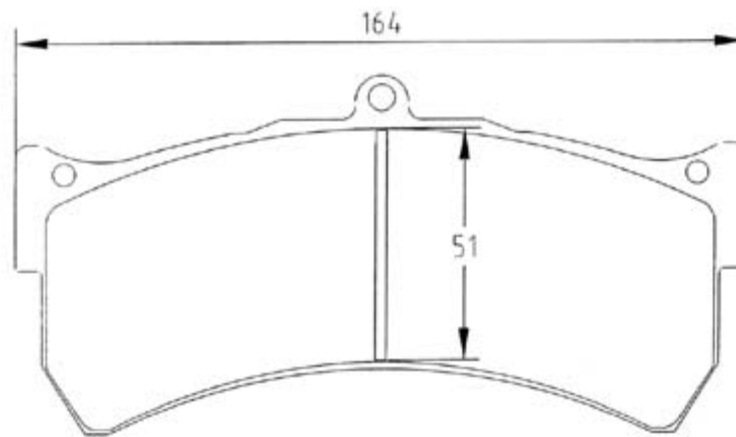

PBF2488

T=29

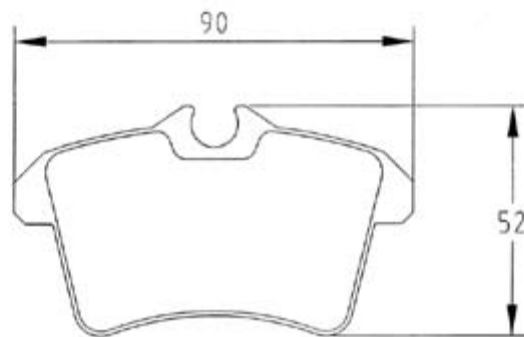

PBF2498

T=15

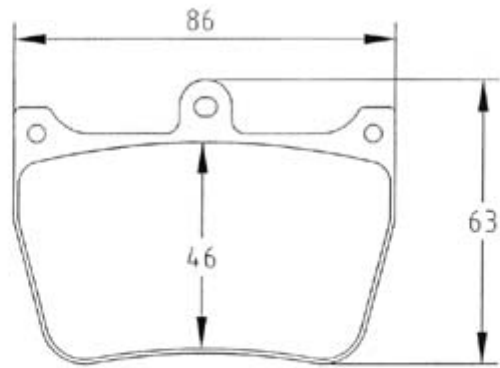

PBF2553

T15

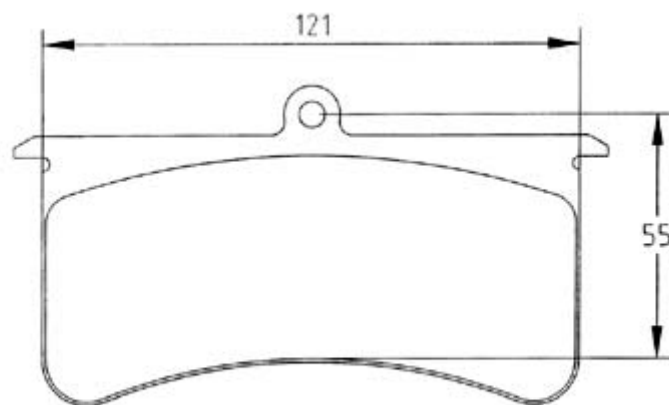

PBF2555

T=20

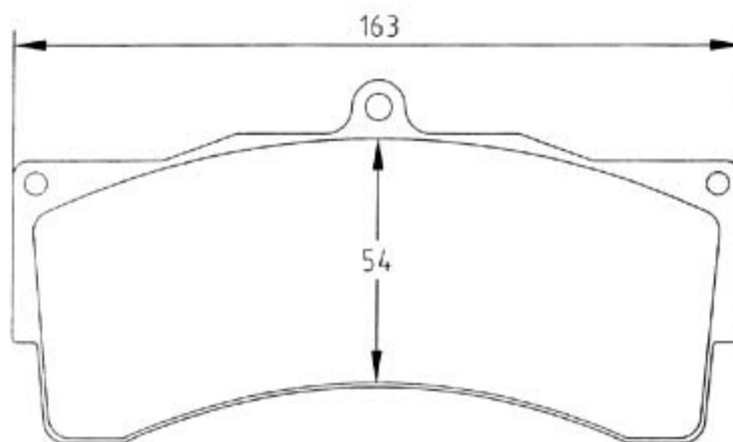

PBF2557

T=29

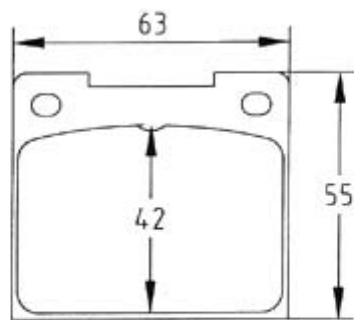

PBF3102

T=14,4

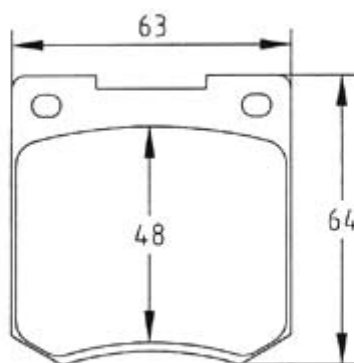

PBF3190

T=14,4

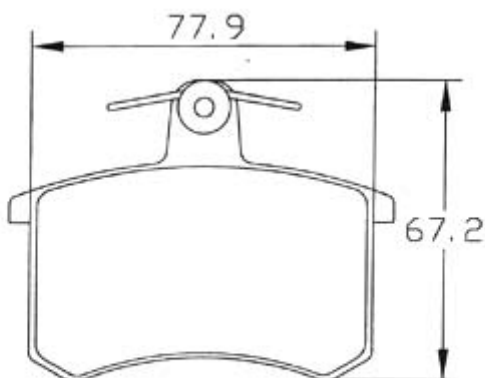

PBF3242

T=15,5

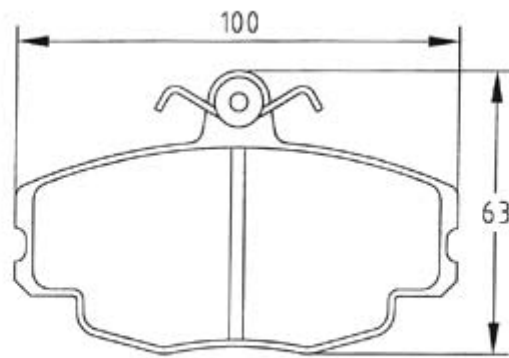

PBF3276

T=18

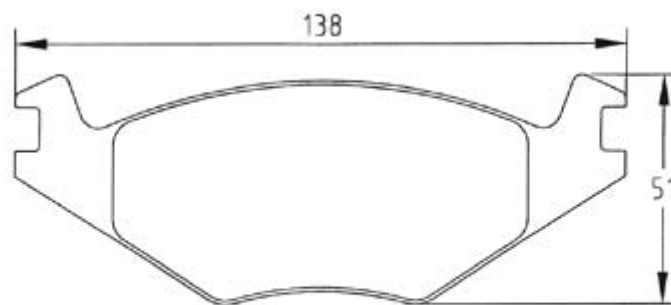

PBF4011
PBF4013

T=15,5

T=19,5

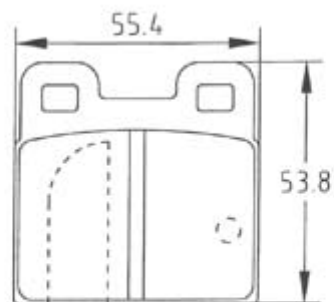

PBF4122

T=14,7

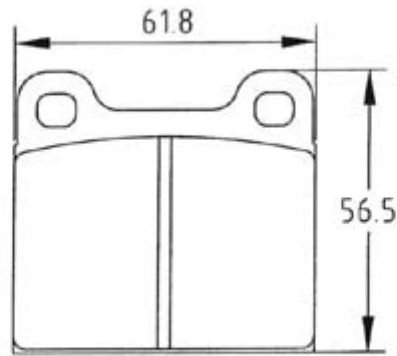

PBF4304

T=15

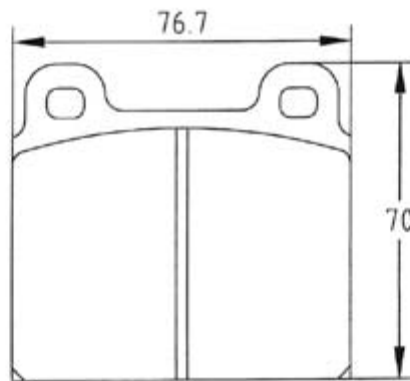

PBF4501

T=15

PBF4503

T=19

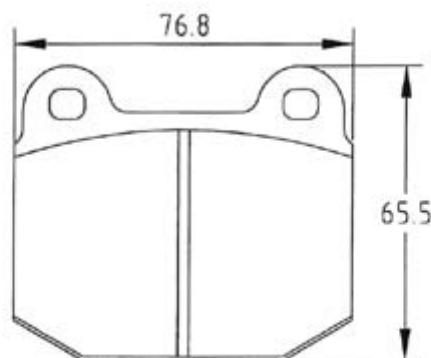

PBF4507

T16,5

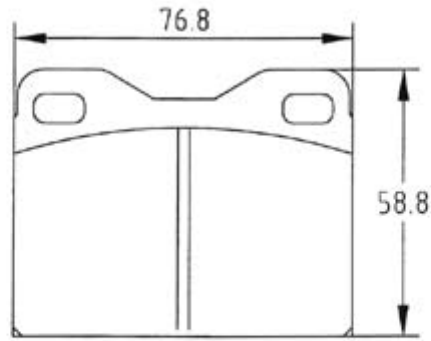

PBF4623
PBF4534

T18,5
T15

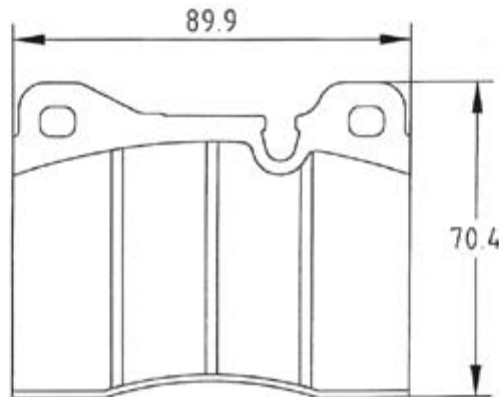

PBF4702
PBF4703

T=19
T=15

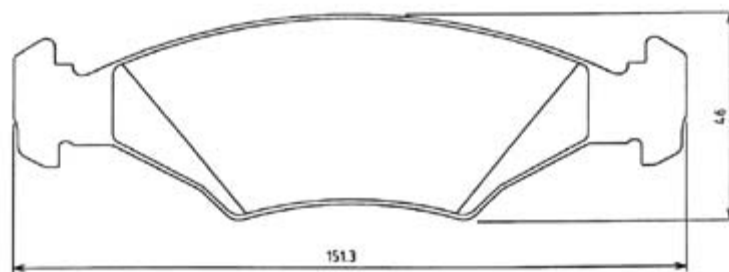

PBF4823

T=18

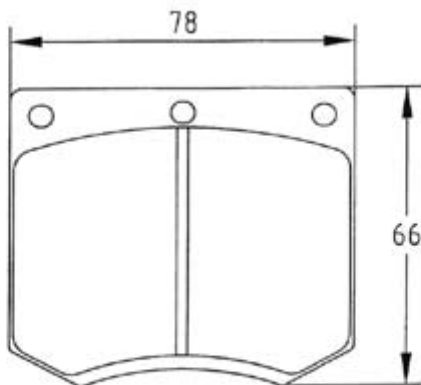

PBF4905

T=15,5

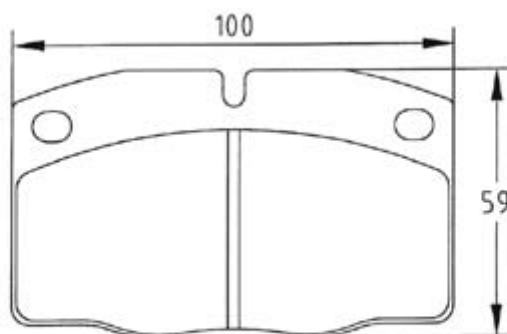

PBF9521

T=15,4

Brake Pad Bedding Procedure

PLEASE NOTE:

IT IS IMPERATIVE THAT THE BEDDING IN PROCEDURES ARE BEING DONE ONLY ON A RACE TRACK. PAGID RACING MATERIAL IS NOT LEGAL FOR STREET USE.

Why bedding?

- To transfer a layer of friction material onto the brake disc faces to achieve maximum performance.
- To stabilize compressible materials to avoid a spongy pedal.
- To boil off volatile elements in the friction compound in order to have the initial 'green' fading during bedding and not during the race.
- To align the pad surface with the brake disc surface to have full contact.

If pads do not get bedded properly and / or used to hard right out of the box will likely lead to pad glazing. Pad glazing is a condition where the resins in the pad crystallize on both, the pad friction surface and the brake disc surface, resulting in poor stopping performance, brake judder and vibrations.

Also rapidly escaping volatile elements and moisture from the resin would seek an immediate escape route out of the friction compound, creating small fissures that would lead shortly to cracking and chunking.

1.) BASIC BEDDING IN

To initiate some heat in the brake discs and pads.

- 4 to 6 stops with medium brake pressure from approximately 150 km/h (90 MPH) to approximately 80 km/h (50 MPH).
- Distance between each brake stop approximately 300 - 400 meters (300 to 400 yards).
- The pads should not reach temperatures above 400° Centigrade (550° Fahrenheit).
- No dragging!
- Blocking of the air ducts might be helpful to reach appropriate temperatures quicker.

2.) IMMEDIATELY AFTER BASIC BEDDING IN AT HIGH SPEED

Simulating race conditions

- One stop with medium to heavy brake pressure, without allowing brakes to lock from approximately 180 km/h (110 MPH) to approximately 80 km/h (50 MPH).
- No dragging!
- Recovery stops with light brake pressure 3 to 4 times. (Cleaning procedure)
- Repeat the high-speed stops including recovery stops 2 to 3 times.

PAGID



- Allow a cool-off distance of approximately 500 m (500 yards) between high-speed stops.

BRAKE DISCS

If possible, pads should be bedded on used but NOT worn out brake discs.
Pagid brake pad material can be used either on solid, grooved or cross-drilled discs.
For disc bedding please refer to the disc manufacturers' own instruction.

MOUNTING NEW PADS ON USED DISCS

Edges of pad surface should be filed roughly to 45 degrees to ensure that the pad carries fully and evenly and is not touching the edge of the disc.
Do not use discs, which are pre-bedded, or have been used with friction material other than PAGID.

Racing Compound Characteristics



RS 4-2-1

RS 4-2-1 Black

A high performance compound with low fading characteristics and high cold friction. The most comfortable medium friction sport compound. Rotor friendly and OE on various Ferrari, Lamborghini, Lotus, Bugatti and Corvette (Callaway) models. Suitable for street and light track use.



RS 4-2

RS 4-2 Blue

A medium friction racing compound with good cold friction and fading resistance up to 500°C (930°F).

The 4-2 compound has an acceptable rotor wear rate and a very good modulation (adjustment). It is a Classic Rally compound and is used also for small Single-Seater (F3, F-Ford, Club Racing and Showroom Stock).



RS 4-4

RS 4-4 Orange

This compound has a very good fade resistance and a higher average friction value than the RS 4-2. It is rotor friendly with predictable, non-aggressive friction behaviour (stable torque). Fading resistance up to 560°C (1.050°F). It is a very good rear compound for Touring Car applications in combination with RS 14 front pads. It's main application is Porsche 911 racing. It is used on either Short Track or Long Distance; also for front and rear axles. It is also used on BMW Showroom Stock, all other Touring-Cars and Single- Seater up to F3.

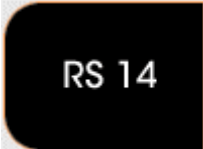

RS 14

RS 14 Black

This is a medium high friction value ceramic type compound with very good modulation, high fade resistance, low heat conductivity, and a good wear rate up to a temperature of 650°C (1.200°F). It is kind on discs, with visible grooving, but a limitation of hairline cracks. Applications: NASCAR, CART, F3, Touring cars, GT cars, WSC, Trans Am and Rally.



RS 15

RS 15 Grey

Very high torque compound. It combines a 20% higher friction value than the RS14 with a slightly increased pad wear. Needs finesse to avoid over braking the car. Good release characteristic. Although the RS15 has a very good modulation (controllability) it might have an excessive bite for some applications, as lightweight cars or cars with boosted brakes. Applications: NASCAR, CART, F3, Touring cars, GT cars, WSC, DP, Trans Am and Rally.



RS 19

RS 19 Yellow

Best compound for endurance racing on the basis of the RS 14. A slight reduction of the friction value improves the modulation (controllability). Nevertheless, the friction value is enough for cars without power-assisted brake system and ensures comfortable low effort on the brake pedal. Constant temperatures up to 600°C (1.100°F) are possible. The combination of friction value, fading stability and low wear rates on pads and discs (rotors) realized with this pad compound is

PAGID



unmatched up to now. Due to its outstanding wear rate and driveability PAGID endurance materials are often used at sprint races as well. A multiple winner of Daytona 24h, Le Mans 24h, Sebring 12h, Spa 24 h, Nürburgring 24h, often with no pad change and usually no disc (rotor) change. Application: All endurance racing cars from group N (Speed-WC, Grand Am Cup) up to GT and Sport-Prototypes (Grand Am DP).

RS 29

RS 29 Yellow

New endurance compound. This compound combines the outstanding wear rate of the RS19 with a slightly higher coefficient of friction and initial bite. Due to its outstanding wear rate and driveability PAGID endurance materials are often used at sprint races as well. Application: All endurance racing cars from group N (Speed-WC, Grand Am Cup) up to GT and Sport-Prototypes (Grand Am DP).