

Rotary knife wood turning lathes: Safeguarding and reducing risks to health

Woodworking Sheet No 28

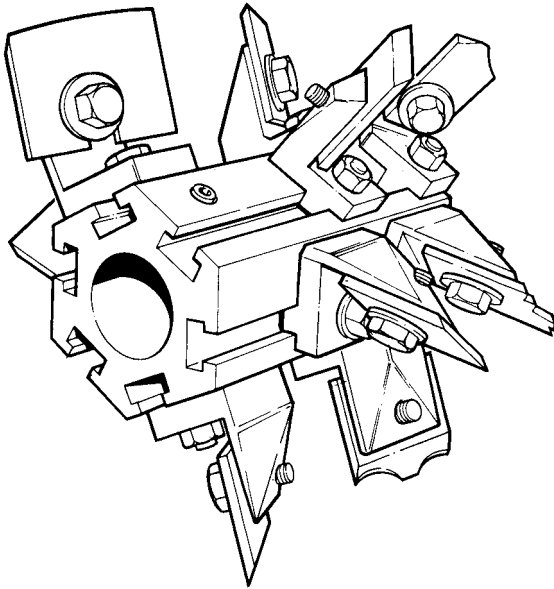

Figure 1 Rotary knife tooling

Introduction

This information sheet is one of a series prepared by HSE's Woodworking National Interest Group (NIG) in agreement with the British Wood Turners' Association, the Handle Manufacturers' Association and the Woodworking Machinery Suppliers' Association. Its purpose is to give guidance to manufacturers, suppliers and users about ways of safeguarding and reducing noise and dust emission at rotary knife wood turning lathes.

Key legal requirements covering the use and supply of these machines are contained in the Supply of Machinery (Safety) Regulations 1992,¹ section 6 of the Health and Safety at Work etc Act (HSW Act) 1974, the Provision and Use of Work Equipment Regulations 1998^{2, 3} the Control of Substances Hazardous to Health (COSHH) Regulations 1999⁴ and the Noise at Work Regulations 1989.⁵

Scope

This guidance refers to the three classes of rotary knife lathe which incorporate a cutter-block on a fixed spindle or arbor, eg a solid block, loose knife cutter-block etc.

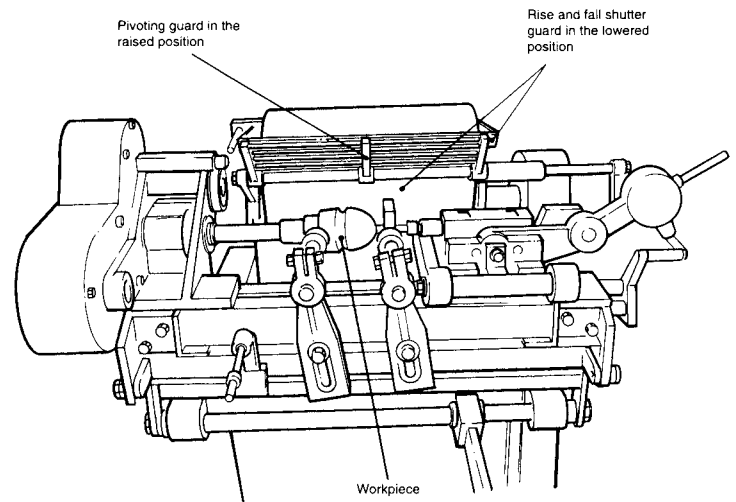

Figure 2 Position of guards during loading of the workpiece

1 The 'manually-operated' lathe, in which a workpiece is located by hand on a saddle and is advanced rotating, by a manually-operated lever, to meet the rapidly rotating cutter, either on a sliding carriage or between swinging arms.

2 The 'semi-automatic' lathe where the machine operates on a single cycle and one or more of the following functions are automated:

- clamping of the workpiece;
- advancing the workpiece onto the cutter-block;
- advancing the cutter-block onto the workpiece;
- magazine loading.

For example, the workpiece is magazine loaded onto the saddle and presented by a manually-operated lever onto the cutter-block, or the workpiece is located by hand and then pneumatically fed onto the cutter-block.

3 The automatic or fully automatic version of the semi-automatic lathe which is magazine fed. The operator has only to feed stock into a magazine or onto

a conveyor and workpieces are discharged automatically on completion.

Accidents

Although the wood turning industry is not large, there have historically been significant numbers of accidents at these machines, sometimes involving loss of several fingers. Accidents are caused when the operator's hand contacts the rotating cutters while attempting to move, adjust or unjam a workpiece, or the operator stumbles and is injured on an inadequately enclosed/unguarded machine. Injuries have also been caused by ejected workpieces and flying cutters.

Hazards and risks

Each machine has its own characteristics which should be considered when identifying the hazards and risks, but all of the following hazards will need to be considered:

- 1 contact with rotating cutters (see Figure 1);
- 2 ejection of the workpiece and/or cutter(s);
- 3 trapping and crushing caused by moving carriages, swinging arms and moving turrets;
- 4 unexpected movement or start-up caused by faults in the automatic cycling of the machine;
- 5 noise emission (often in excess of 100 dB(A));
- 6 exposure to dust and chippings (often in excess of the maximum exposure limit (MEL) of 5 mg/m³ (milligrammes per cubic metre) for hardwood and softwood dust).

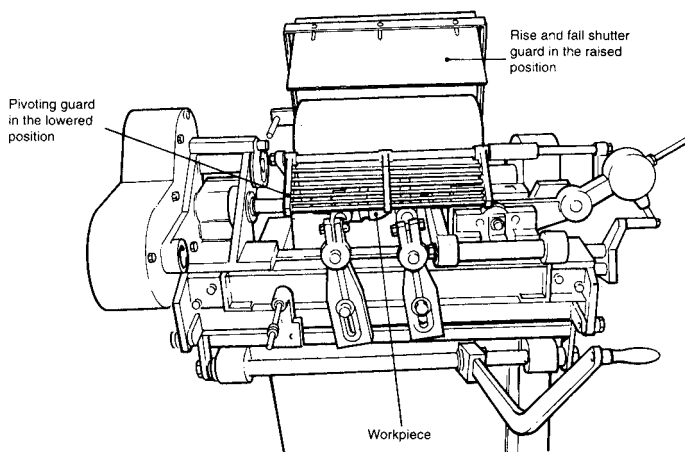

Figure 3 Position of guards during machining of the workpiece

Guarding

New machines should be designed so that, during normal operation, contact with cutters is prevented by effective enclosure of the cutter head.

Access to cutters should be prevented by a interlocked guard with guard locking which cannot be opened unless the cutters are at rest. Guard locking on interlocked guards will not be required if the machine is fitted with an automatic brake which stops the tool in a sufficiently short time.

All transmission machinery and other dangerous parts should be safeguarded. The standards specified in BS EN 292-1⁶ and BS EN 292-2⁷ represent one way of meeting legal requirements.

Existing machines should be modified to achieve the standards of new machines where this is practicable, eg through automation, by the addition of magazine/ conveyor feeding. Automation upgrading is available from the manufacturers for several common models.

Where it is not practicable to meet the standard for new machines, a rise and fall shutter guard should be provided at manually-operated and semi-automatic machines. This should be linked with the saddle feed mechanism so that the cutter is enclosed at all times when cutting is not taking place (see the example in Figure 2). An additional guard should also be linked with the saddle feed mechanism so that access to the cutter-block and workpiece during cutting is prevented.

One example is a pivoting guard which when lowered prevents contact with the cutter-block and workpiece even though the rise and fall shutter guard is in the raised position. When the rise and fall shutter guard is in the lowered position the pivoting guard swings out of the way to allow loading of the next workpiece (see Figure 3).

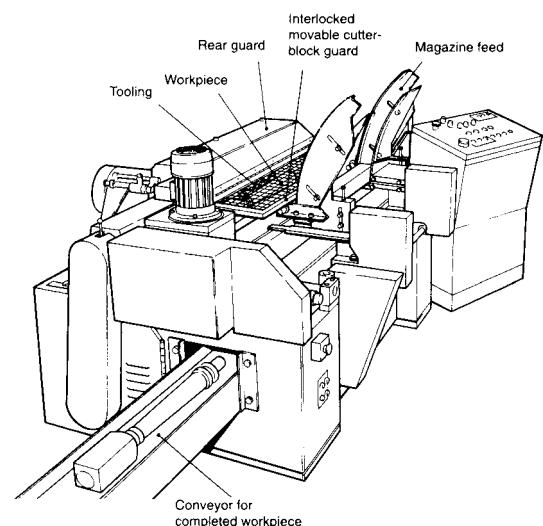

Figure 4 Interlocked movable cutter-block guard preventing access to tooling while machining

A similar device should be provided on all machines where there is a danger of operator contact and where other measures are not taken (see Figure 4).

Noise

New machines should be designed to minimise noise emission. See HSE Woodworking Information Sheet WIS13.⁸ Priority should be given to control of noise at source, eg by the development of low noise cutter design, optimising tool rotation speed etc.

Residual high noise levels (equal to or greater than 85 dB(A)) should be reduced, so far as is reasonably practicable, by integrating an acoustic enclosure within the design of the machine.⁹ Machinery noise levels should be declared and, if residual noise is at hazardous levels, prospective purchasers should be warned of this hazard.

Existing machines should be modified to achieve the standards of new machines, where this is reasonably practicable. This is likely to require the fitting of full interlocked enclosures on automatic machines, and semi-automatic machines which are magazine fed (see Figure 5).

Enclosures fitted to other types of semi-automatic and manually-operated machines may require sliding access panels or partially open fronts to allow loading of the workpiece, visual inspection and access.

Wood dust and chippings

New machines should be designed to extract wood waste efficiently. The levels of total inhalable dust in the operator's breathing zone should be as low as practicable and should be below the maximum exposure limit (MEL) of 5 mg/m³ for hardwood and softwood dust.¹⁰

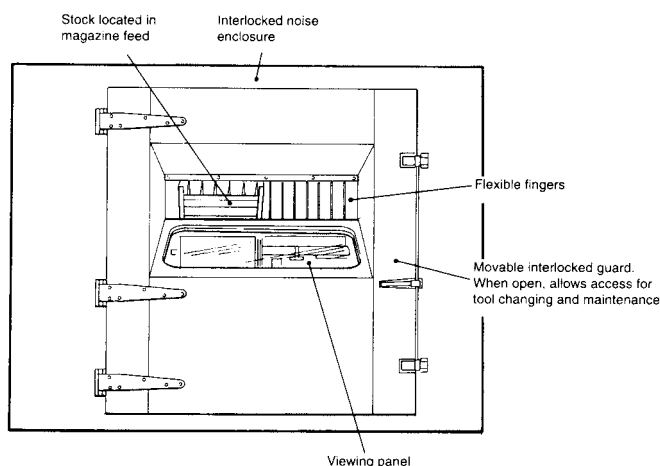

Figure 5 Interlocked noise enclosure

Captor hoods should be designed to capture and be placed as close as possible to the point of generation of the dust-laden air-stream. They should also be designed to take advantage of the natural air movement created by the machine.

The use of extraction guide vanes will reduce turbulence and improve extraction efficiency, particularly at machines where the direction of air flow caused by the tool is different from that caused by the extraction system.

The most effective design would allow automatic feeding through an integrated interlocked noise enclosure, incorporating an effective extraction system.

Existing machines should be modified to meet the standards of new machines, where this is reasonably practicable.¹¹ The levels of total inhalable dust in the operator's breathing zone should be as low as reasonably practicable, and should be below 5 mg/m³. Suitable respiratory protective equipment (RPE)¹² may be needed as an interim measure, for example, where engineering controls are under development and operator's exposures to wood dust exceed 5 mg/m³ or are not as low as reasonably practicable. 'Nuisance dust masks' are not appropriate for use.

Ejection of cutters

The risk of flying cutters should be minimised. In some cases, this may be achieved by positive retention, where the cutters are held by bolts through closed slots.

A safe system of work should be specified for the tool setter, including the identification of manufacturers' torque settings for each type of tooling used.

Torque wrenches should be used to minimise the risk of flying cutters, particularly as a consequence of over-tightening or under-tightening bolts. Only suitable high-tensile bolts should be used.

Maintenance

Cutters, cutter mountings and associated bolts should be kept in good condition and visually inspected at frequent intervals. Components appearing defective should be repaired or replaced. The integrity of engineering controls and noise enclosures should be regularly checked.

The effectiveness of any wood waste extraction control system depends on its performance being routinely monitored. Defects should be reported and corrected. The control system should also be thoroughly inspected and tested by a competent person at least once every fourteen months.

Training and systems of work

It is vital that machine operators are properly trained.³ Only operators who have been authorised, ideally in writing, as properly trained and competent, should be allowed to operate machines. Adequate instruction and supervision are also important.

Setters require particularly detailed training and experience before taking responsibility for cutter setting.

An appropriate system should be introduced to ensure that knife security is systematically checked before start-up of any machine.

References

1 *Product standards - Machinery - Guidance notes on UK Regulations* (May 1995) DTI URN 95/650. Copies available free from the DTI's Business in Europe Hotline on 0870 150 2500

2 *Safe use of work equipment. Provision and Use of Work Equipment Regulations 1998. Approved Code of Practice and guidance* L22 HSE Books 1998 ISBN 0 7176 1626 6

3 *Safe use of woodworking machinery. Provision and Use of Work Equipment Regulations 1998 as applied to woodworking machinery. Approved Code of Practice and guidance* L114 HSE Books 1998 ISBN 0 7176 1630 4

4 *General COSHH ACOP, Carcinogens ACOP and Biological Agents ACOP. Control of Substances Hazardous to Health Regulations 1999. Approved Codes of Practice* L5 HSE Books 1999 ISBN 0 7176 1670 3

5 *Reducing noise at work. Guidance on the Noise at Work Regulations 1989* L108 HSE Books 1998 ISBN 0 7176 1511 1

6 BS EN 292-1: 1991 *Safety of machinery - Basic concepts, general principles for design. Safety of machines Part 1: Basic terminology, methodology*

7 BS EN 292-2: 1991 *Safety of machinery - Basic concepts, general principles for design. Safety of machines Part 2: Technical principles and specifications*

8 *Noise at woodworking machines* Woodworking Information Sheet WIS13 HSE Books 1997

9 *Noise reduction at multi-spindle planing and moulding machines* Woodworking Information Sheet WIS8 HSE Books 1992

10 *Wood dust: Hazards and precautions* Woodworking Information Sheet WIS1(rev1) HSE Books 1997

11 *LEV: General principles of system design* Woodworking Information Sheet WIS23 HSE Books 1992

12 *Selection of respiratory protective equipment suitable for use with wood dust* Woodworking Information Sheet WIS14 HSE Books 1997

While every effort has been made to ensure the accuracy of the references listed in this publication, their future availability cannot be guaranteed.

Further information

HSE priced and free publications are available by mail order from HSE Books, PO Box 1999, Sudbury, Suffolk CO10 2WA Tel: 01787 881165 Fax: 01787 313995 Website: www.hsebooks.co.uk (HSE priced publications are also available from bookshops.)

British Standards are available from BSI Customer Services, 389 Chiswick High Road, London W4 4AL Tel: 020 8996 9001 Fax: 020 8996 7001 Website: www.bsi-global.com

For information about health and safety ring HSE's InfoLine Tel: 08701 545500 Fax: 02920 859260 e-mail: hseinformationservices@natbrit.com or write to HSE Information Services, Caerphilly Business Park, Caerphilly CF83 3GG. You can also visit HSE's website: www.hse.gov.uk

This leaflet contains notes on good practice which are not compulsory but which you may find helpful in considering what you need to do.

This publication may be freely reproduced, except for advertising, endorsement or commercial purposes. The information is current at 10/94. Please acknowledge the source as HSE.